

# CYKLOP 2

PL INSTRUKCJA UŻYTKOWANIA

EN MANUAL INSTRUCTION

CZ NÁVOD K OBSLUZE

## ZANIM ZACZNIESZ

Dziękujemy za wybór produktu Marki HMS, Modelu Cyklop 1. Mając na uwadze własne bezpieczeństwo i korzyści zapoznaj się dokładnie z tą instrukcją przed użyciem przyrządu. Jako producent dążymy do zagwarantowania naszym klientom pełnej satysfakcji.

## WAŻNE WSKAZÓWKI DOTYCZĄCE BEZPIECZEŃSTWA

Produkt ten przeznaczony jest wyłącznie do użytku domowego i zaprojektowano go tak, aby zapewnić optymalne bezpieczeństwo. Powinny być przestrzegane następujące zasady:

1. Przed rozpoczęciem treningu skonsultuj się z lekarzem w celu stwierdzenia braku przeciwwskazań do korzystania ze sprzętu do ćwiczeń. Decyzja lekarza jest niezbędna w przypadku przyjmowania leków wpływających na pracę serca, ciśnienie krwi i poziom cholesterolu. Jest to także konieczne w przypadku osób w wieku powyżej 35 lat oraz osób mających kłopoty ze zdrowiem.
2. Przed rozpoczęciem ćwiczeń zawsze wykonaj rozgrzewkę.
3. W czasie ćwiczeń i po ich zakończeniu zabezpiecz sprzęt treningowy przed dostępem dzieci i zwierząt.
4. Urządzenie należy postawić na suchej, stabilnej i właściwie wypoziomowanej powierzchni. Z bezpośredniego sąsiedztwa urządzenia należy usunąć wszystkie ostre przedmioty. Należy chronić je przed wilgocią, ewentualne nierówności podłoża należy wyrównać. Zalecane jest stosowanie specjalnego podkładu antypoślizgowego, który zapobiegnie przesuwanemu się urządzenia podczas wykonywania ćwiczeń.
5. Wolna przestrzeń nie powinna być mniejsza niż 0,6 m i większa niż powierzchnia treningowa w kierunkach, w których sprzęt jest dostępny. Wolna przestrzeń musi także zawierać przestrzeń do awaryjnego zejścia. Gdzie sprzęt jest usytuowany obok siebie, wielkość wolnej przestrzeni może być podzielona.
6. Zwracaj uwagę na niepokojące sygnały. Niewłaściwe lub nadmierne ćwiczenia są niebezpieczne dla zdrowia. Jeśli w czasie ćwiczeń pojawią się bóle lub zawroty głowy, ból w klatce piersiowej, nieregularny rytm serca lub inne niepokojące objawy, należy natychmiast przerwać ćwiczenia i skonsultować się z lekarzem. Urazy mogą wynikać z nieprawidłowego lub zbyt intensywnego treningu.
7. Przed pierwszym użyciem, a później w regularnych odstępach czasu, należy sprawdzać mocowanie wszystkich śrub, bolców i pozostałych połączeń.
8. Przed rozpoczęciem ćwiczeń sprawdź umocowanie części i łączących je śrub. Trening można rozpocząć tylko wtedy, jeżeli urządzenie jest całkowicie sprawne.
9. Urządzenie powinno być regularnie sprawdzane pod względem zużycia i uszkodzeń tylko wtedy będzie ono spełniało warunki bezpieczeństwa. Szczególną uwagę należy zwrócić na uchwyty piankowe, zaślepki na nogi i tapicerkę, które ulegają najszybszemu zużyciu. Uszkodzone części należy natychmiast naprawić lub wymienić do tego czasu nie wolno używać urządzenia do treningu.
10. Nie wkładaj w otwory żadnych elementów.
11. Zwracaj uwagę na wystające urządzenia regulacyjne i inne elementy konstrukcyjne, które mogłyby przeszkadzać w trakcie ćwiczeń.
12. Sprzęt wykorzystuj jedynie zgodnie z przeznaczeniem. Jeśli któraś z części ulegnie uszkodzeniu bądź zużyciu lub też usłyszysz niepokojące dźwięki podczas używania sprzętu, natychmiast przerwij ćwiczenia. Nie używaj sprzętu ponownie dopóki problem nie zostanie usunięty.
13. Ćwicz w wygodnym ubraniu i sportowym obuwiu. Unikaj luźnych ubrań, którymi można zahaczyć o wystające części sprzętu lub które mogłyby ograniczać swobodę ruchów.
14. Sprzęt zaliczony został do klasy H według normy EN ISO 20957-1 i jest przeznaczony wyłącznie do użytku domowego. Nie może być używany w celach terapeutycznych, rehabilitacyjnych i komercyjnych.
15. Podczas podnoszenia lub przenoszenia sprzętu należy zachować właściwą postawę, aby nie uszkodzić kręgosłupa.
16. Produkt jest przeznaczony wyłącznie dla osób dorosłych. Trzymaj dzieci, nie będące pod nadzorem z dala od urządzenia.
17. Montując urządzenie należy ściśle stosować się do załączonej instrukcji i używać tylko części dołączonych do zestawu. Przed rozpoczęciem montażu, należy sprawdzić czy wszystkie części, które zawiera dołączona lista, znajdują się w zestawie.

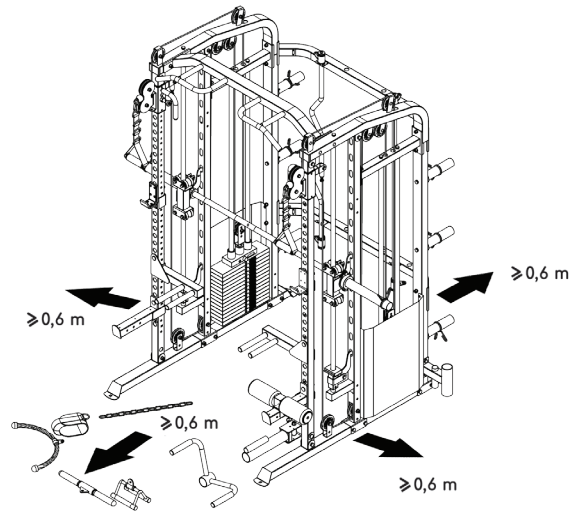

**!** OSTRZEŻENIE: PRZED UŻYCIEM SPRZĘTU FITNESS PRZECZYTAJ INSTRUKCJE.

NIE PONOSIMY ODPOWIEDZIALNOŚCI ZA KONTUZJE LUB USZKODZENIA PRZEDMIOTÓW, KTÓRE ZOSTAŁY SPOWODOWANE NIEWŁAŚCIWYM UŻYTKOWANIEM TEGO PRODUKTU.

**KONSERWACJA:** Do czyszczenia urządzenia nie należy używać agresywnych środków czyszczących. Używaj miękkiej, wilgotnej ściereczki do usuwania zabrudzeń i kurzu. Urządzenia należy przechowywać w miejscach suchych by chronić je przed wilgocią i korozją.

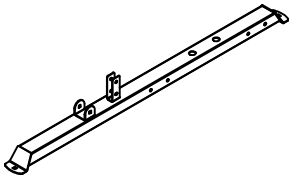

① × 2

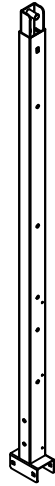

② × 1

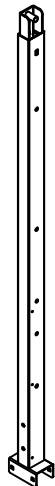

③ × 1

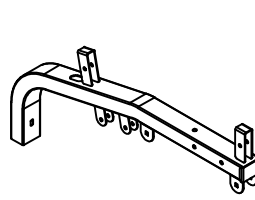

④ × 2

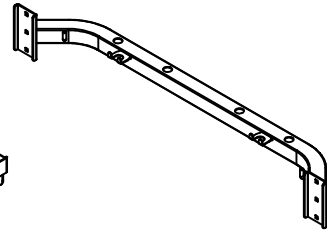

⑤ × 2



⑥ × 4



⑦ × 2

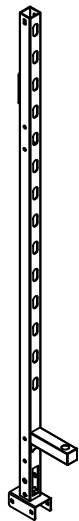

⑧ × 2



⑨ × 2

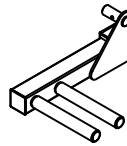

⑩ × 1

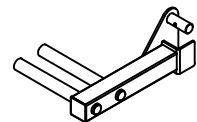

⑪ × 1

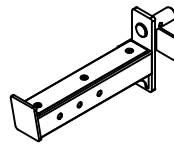

⑫ × 1

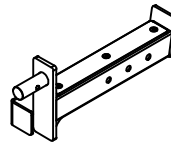

⑬ × 1



⑭ × 1



⑮ × 1

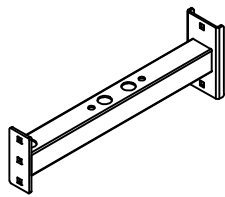

⑯ × 2

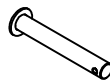

⑰ × 1

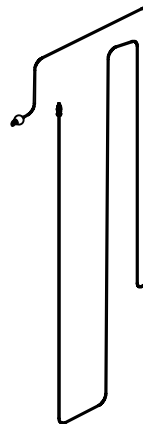

⑱ × 2

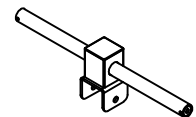

⑲ × 1

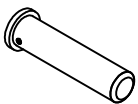

⑳ × 6

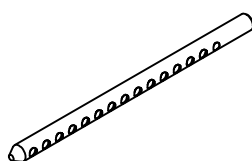

㉑ × 2

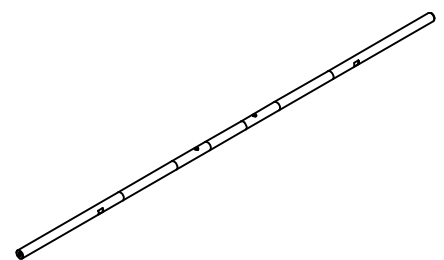

㉒ × 1

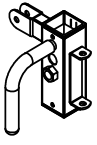

23 × 1

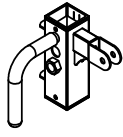

24 × 1

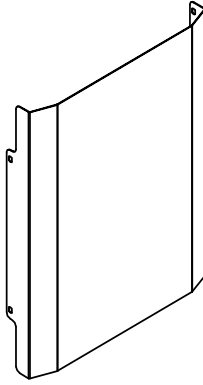

25 × 2

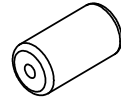

26 × 2

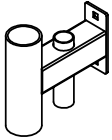

27 × 1



28 × 2

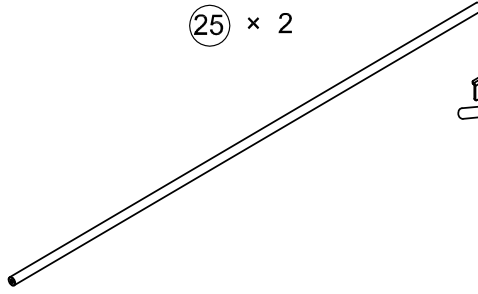

29 × 2

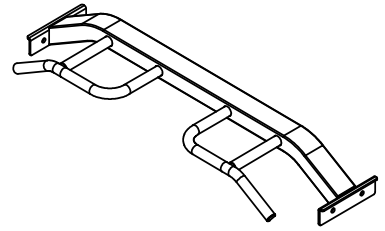

30 × 1



31 × 1



32 × 1



33 × 2

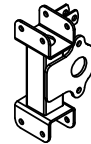

34 × 1



35 × 1

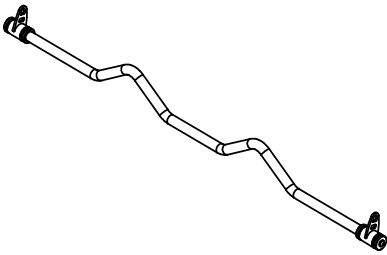

36 × 1

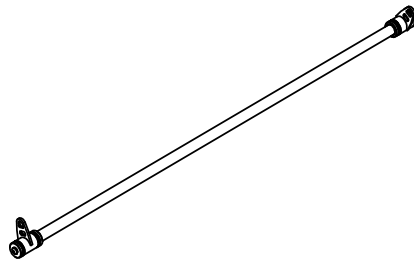

37 × 1

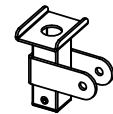

40 × 2

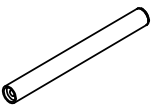

41 × 6

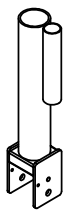

42 × 1

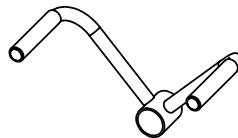

43 × 1

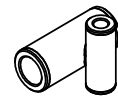

44 × 1

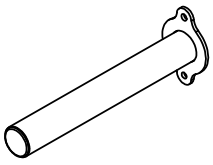

49 x 2

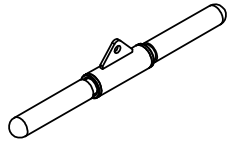

50 x 1



54 x 2

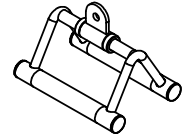

55 x 1



57 x 8

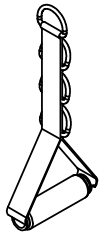

58 x 2



59 x 1

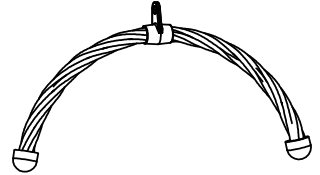

60 x 1



61 x 16



62 x 2

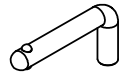

66 x 1



68 x 2



69 x 2



71 x 2



74 x 1



75 x 2

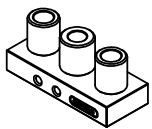

76 x 2

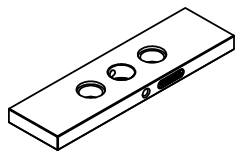

77 x 28



78 x 2



79 x 2



84 x 4



85 x 2



93 x 2



92 x 2

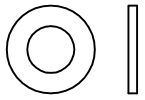

①①① × 10

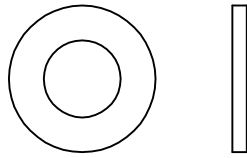

①①③ × 142

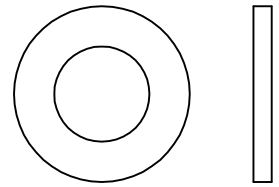

①①④ × 6

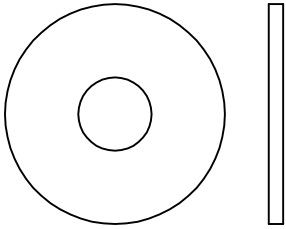

①①⑤ × 4

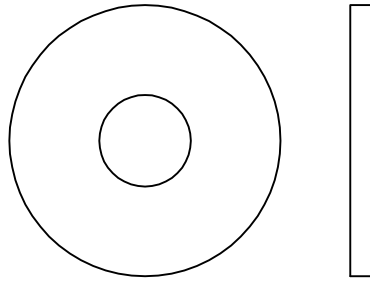

①①⑤ × 2

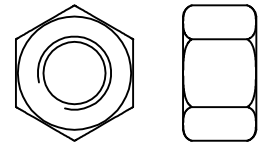

①①⑥ × 64

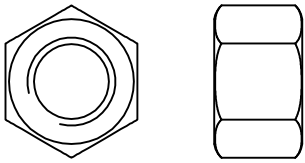

①①④ × 3

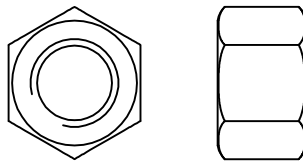

①①④ × 2

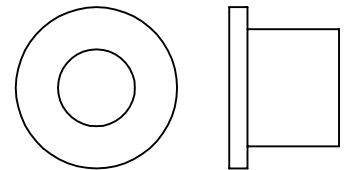

①①⑦ × 4

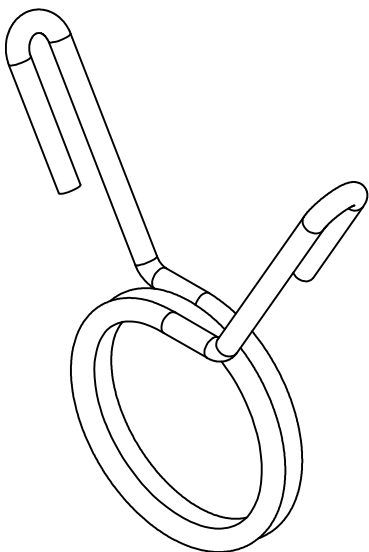

①①③ × 8

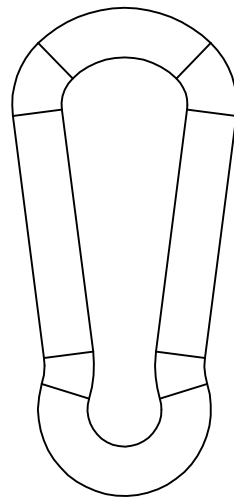

①①⑤ × 2

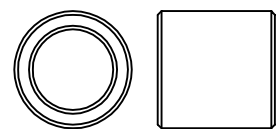

①①⑦ × 4

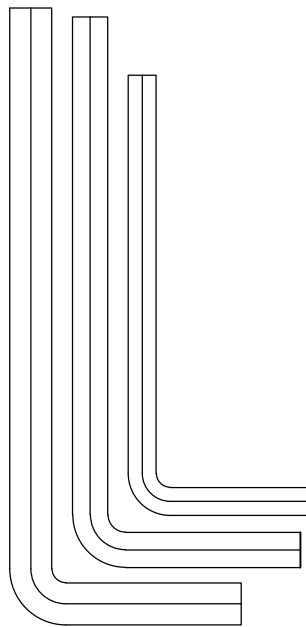
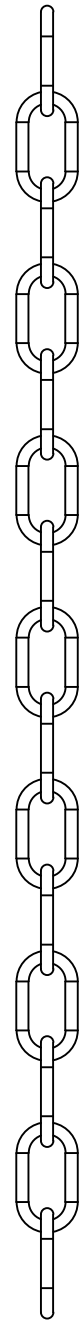
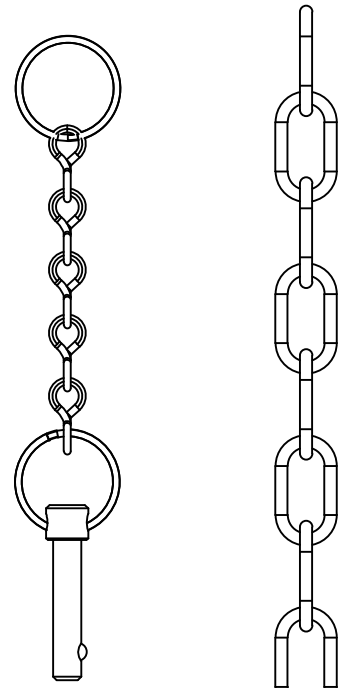
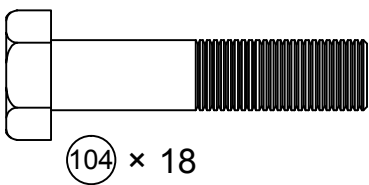
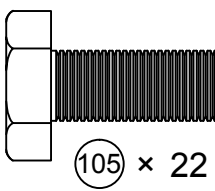
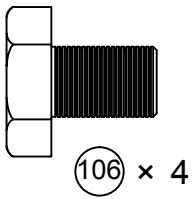
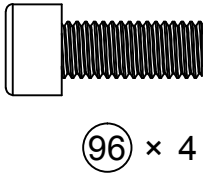
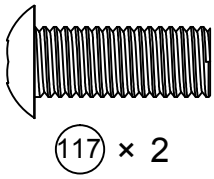
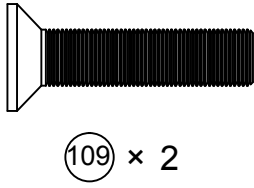
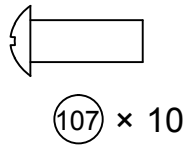

4# × 1

5# × 1



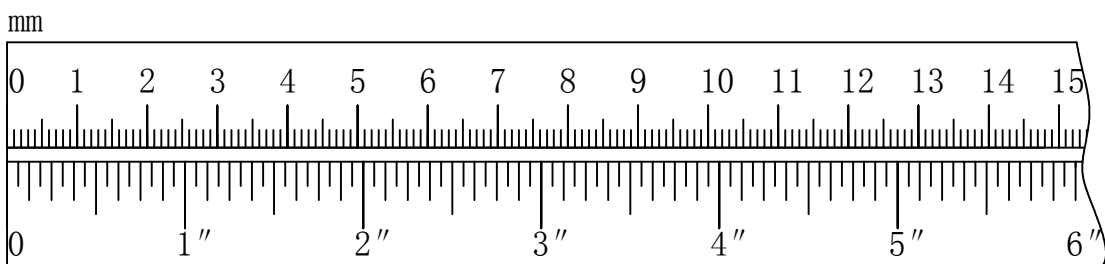

6# × 1

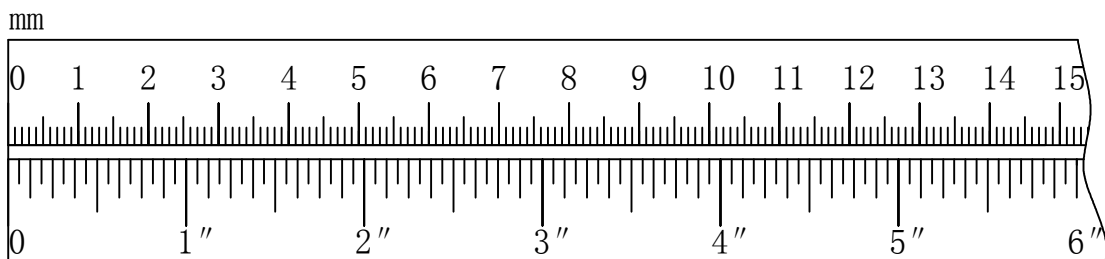
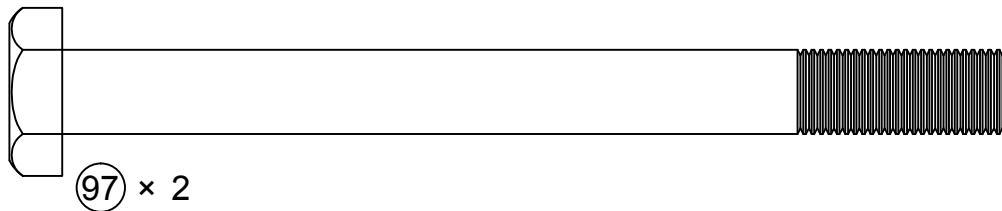
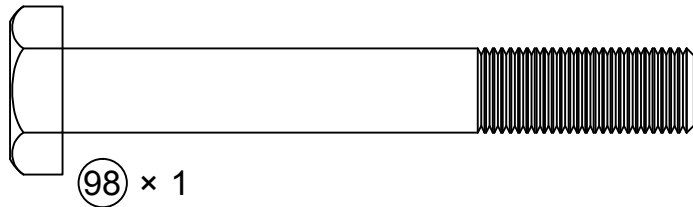
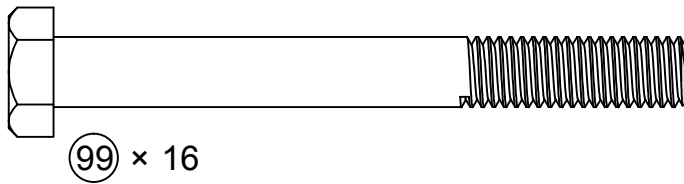
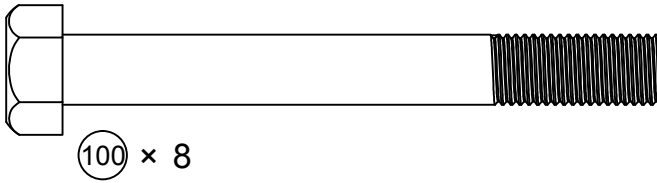
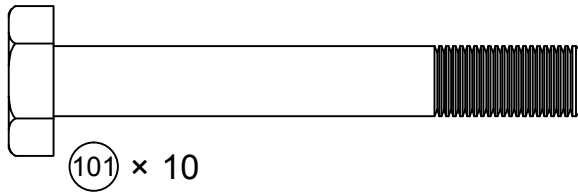
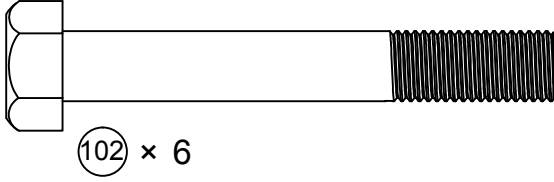
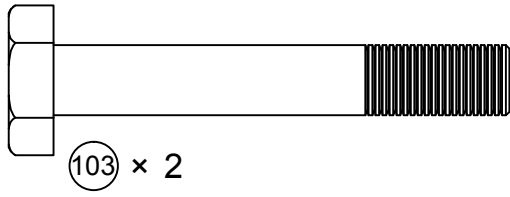
⑦3 × 1



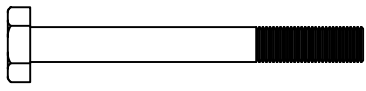





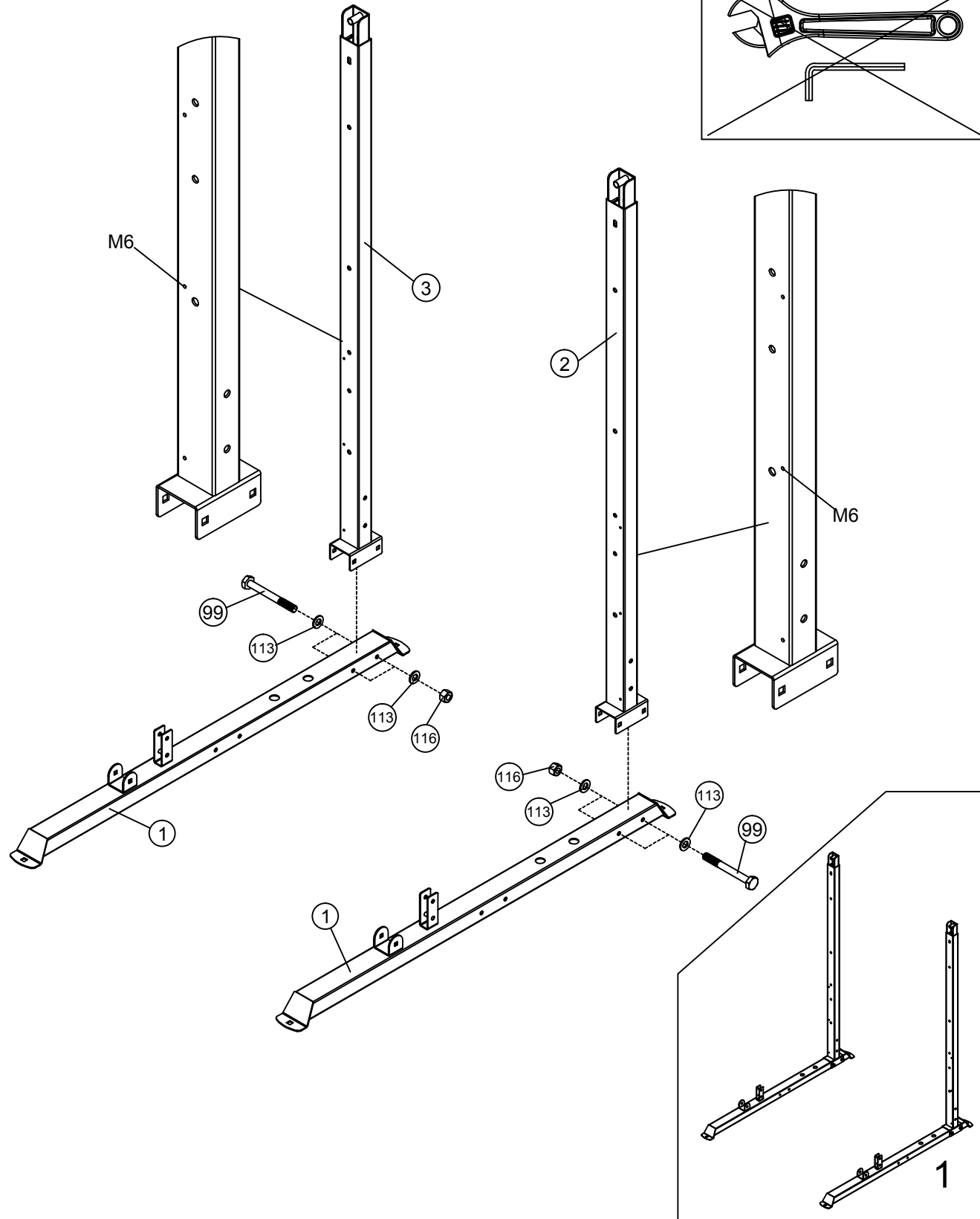
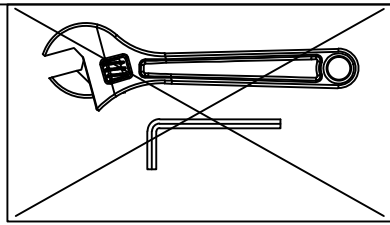

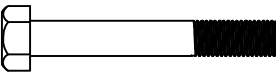

- ⑨⑨  ×4 M10× 90mm
- ①①③   ×8 Φ10
- ①①⑥   ×4 M10

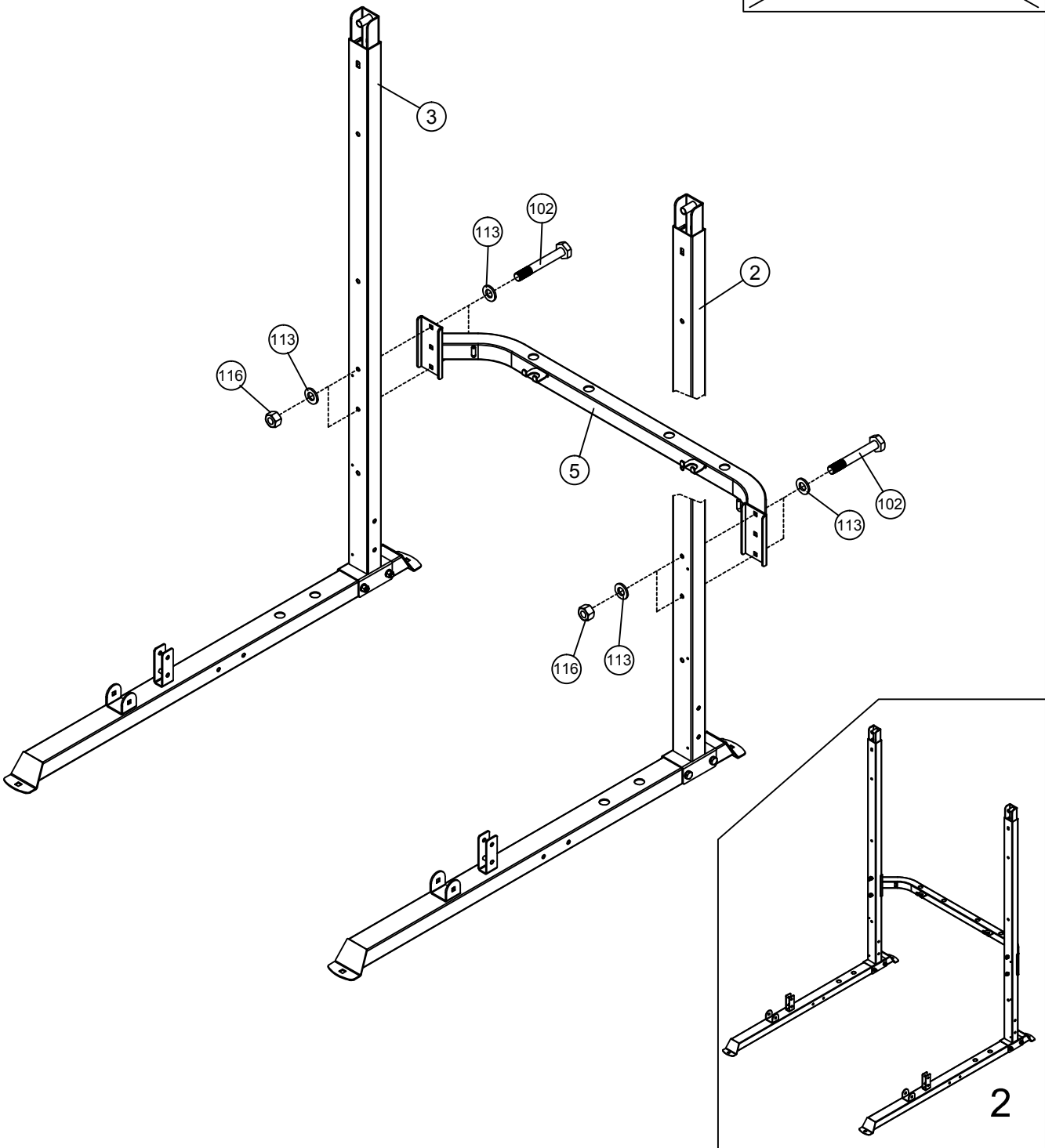
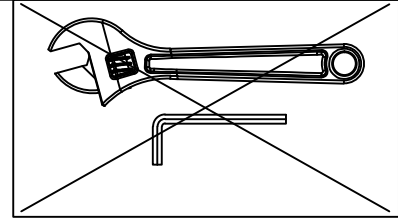

- |     |   |    |           |     |   |    |     |
|-----|---|----|-----------|-----|---|----|-----|
| 102 |  | x4 | M10x 70mm | 113 |  | x8 | Φ10 |
| 116 |  |    |           |     |    | x4 | M10 |

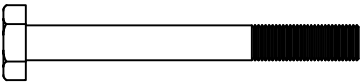
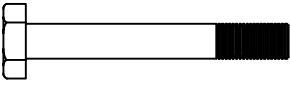

- 99  ×4 M10× 90mm
- 101  ×2 M10× 75mm
- 113  ×12 Φ10
- 116  ×6 M10

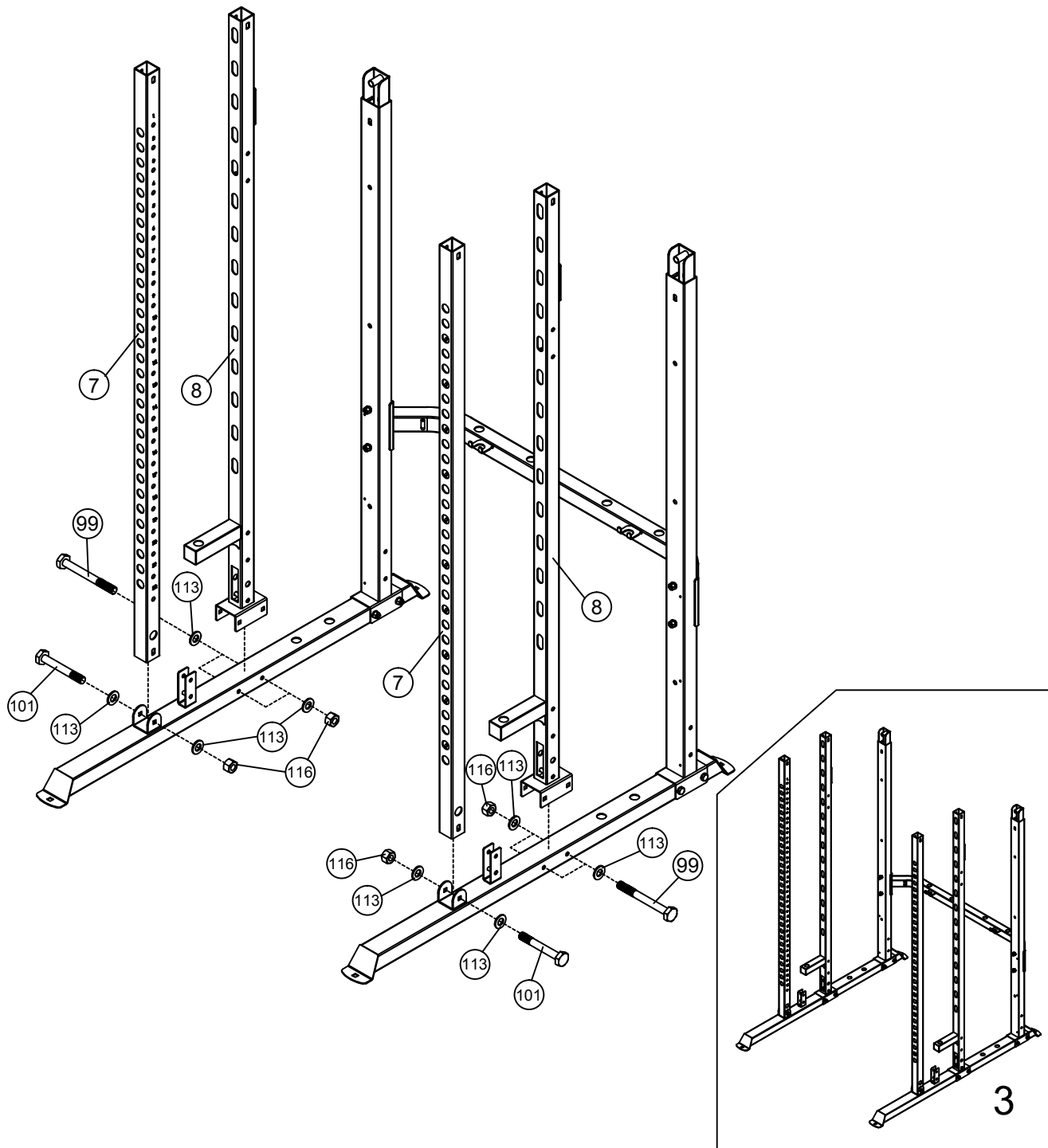
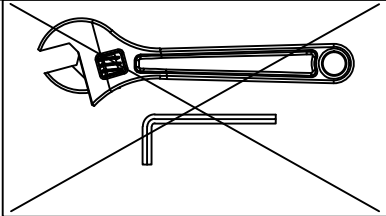



×10 M6× 16mm



×10 Φ6

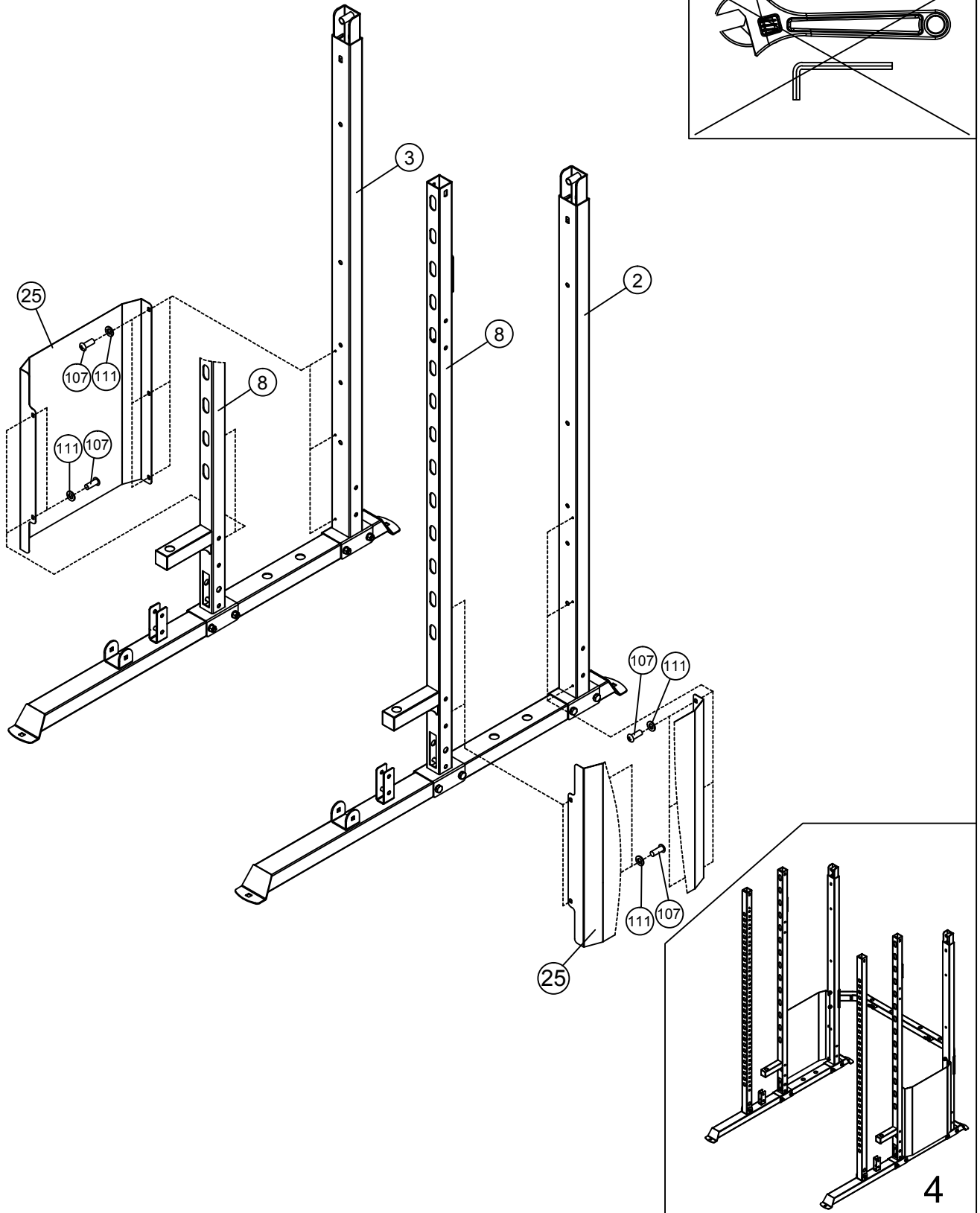
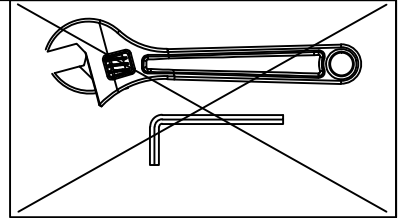

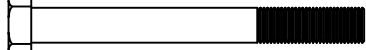

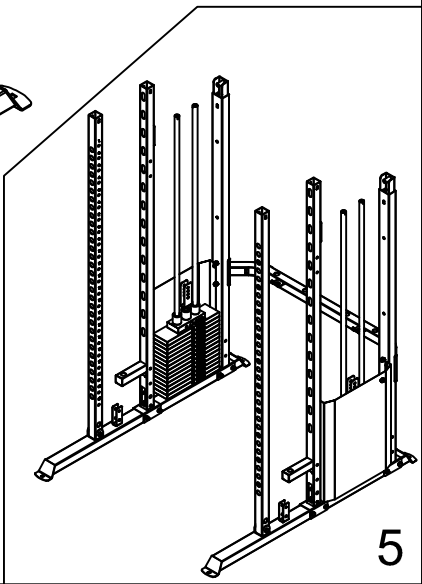
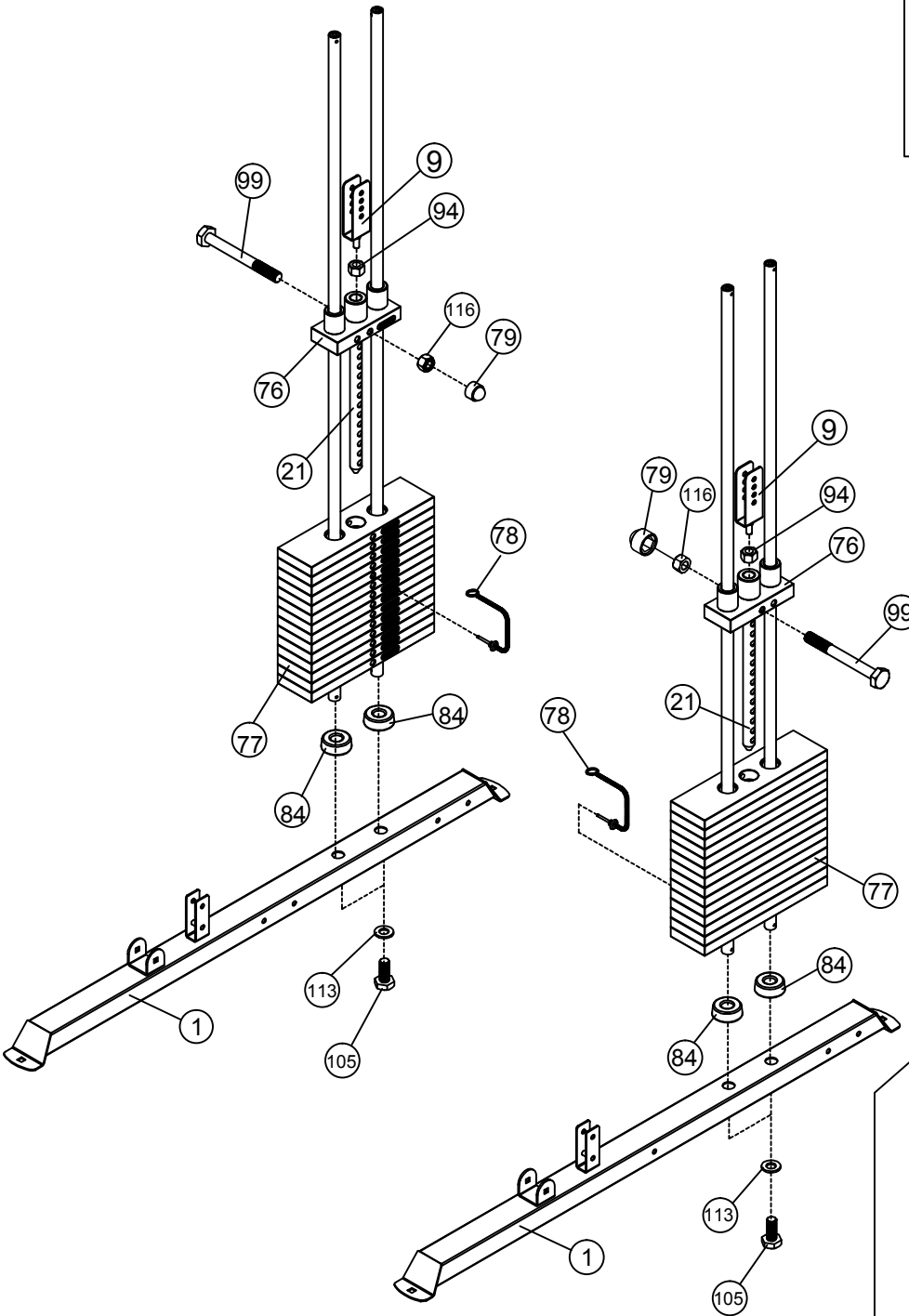
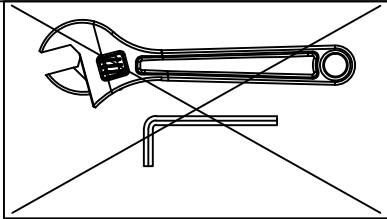
- |     |   |    |           |     |   |   |    |     |
|-----|---|----|-----------|-----|---|---|----|-----|
| 99  |  | ×2 | M10× 90mm | 113 |  |  | ×4 | Φ10 |
| 105 |  | ×4 | M10× 25mm | 116 |  |  | ×2 | M10 |
| 94  |  |    | ×2        | M12 |   |   |    |     |

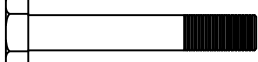

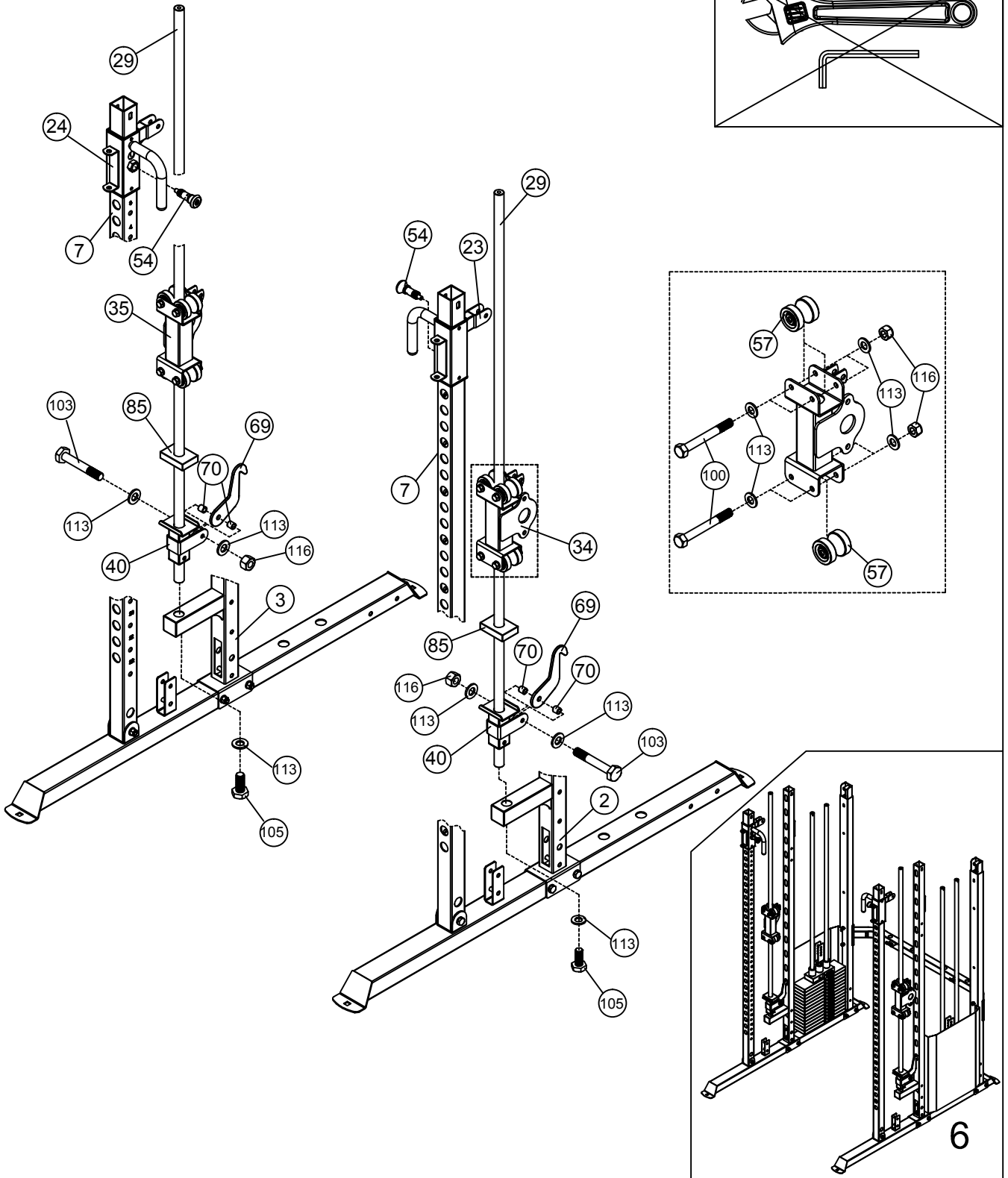
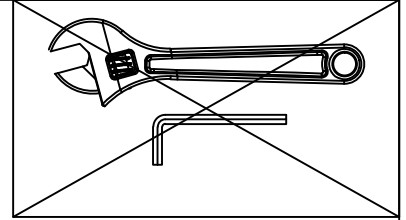
(100)		×8	M10× 100mm	(113)		×22	Φ10
(103)		×2	M10× 65mm	(116)		×10	M10
(105)		×2	M10× 25mm				





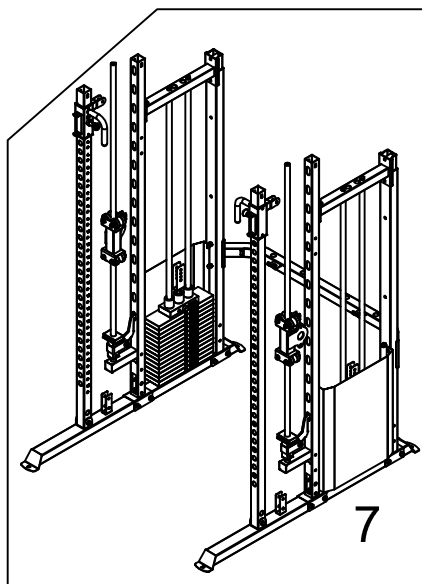
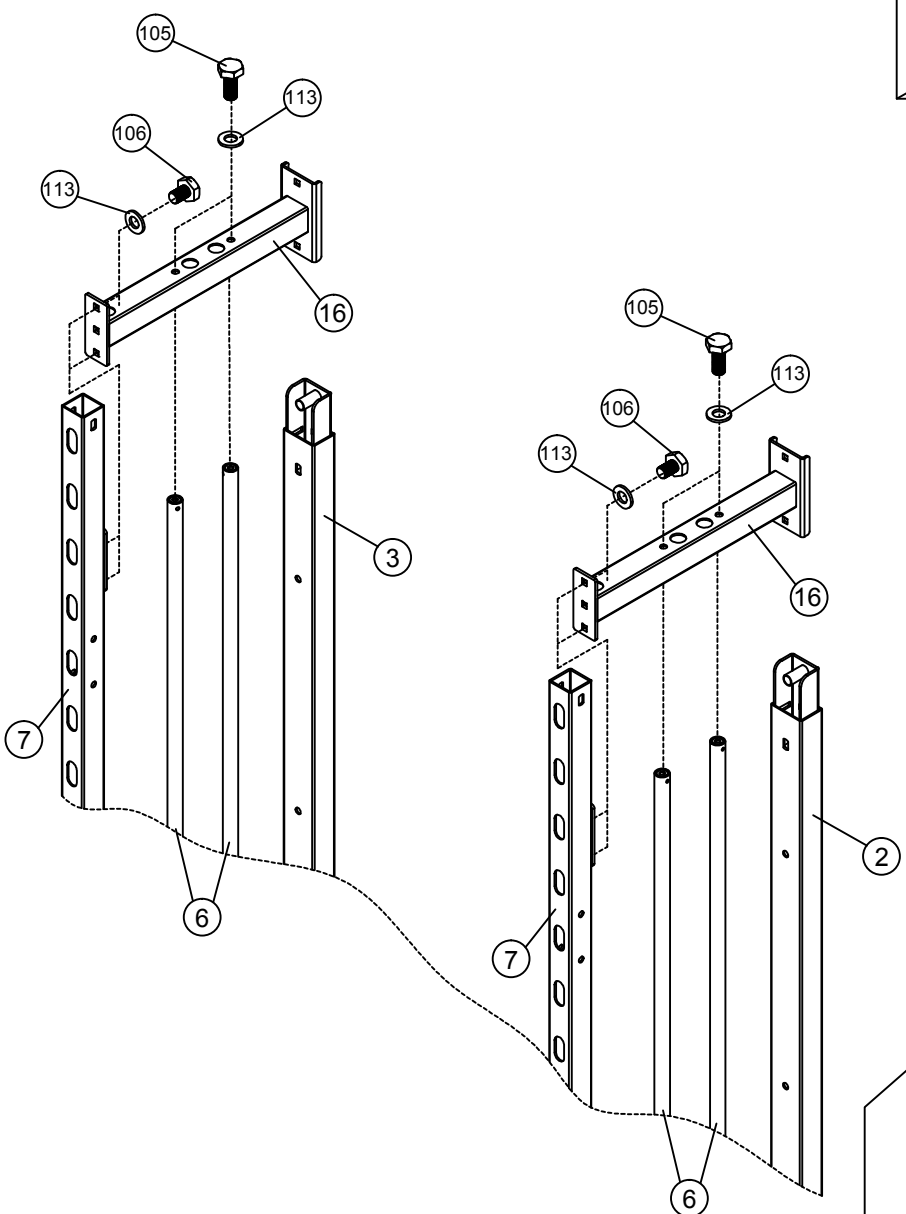
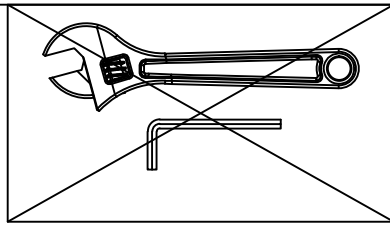

105  ×4 M10× 25mm

113   ×8 Φ10

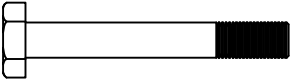
106  ×4 M10× 15mm

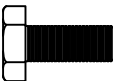



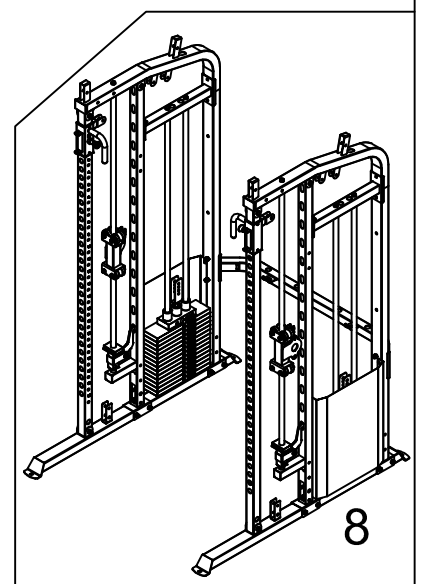
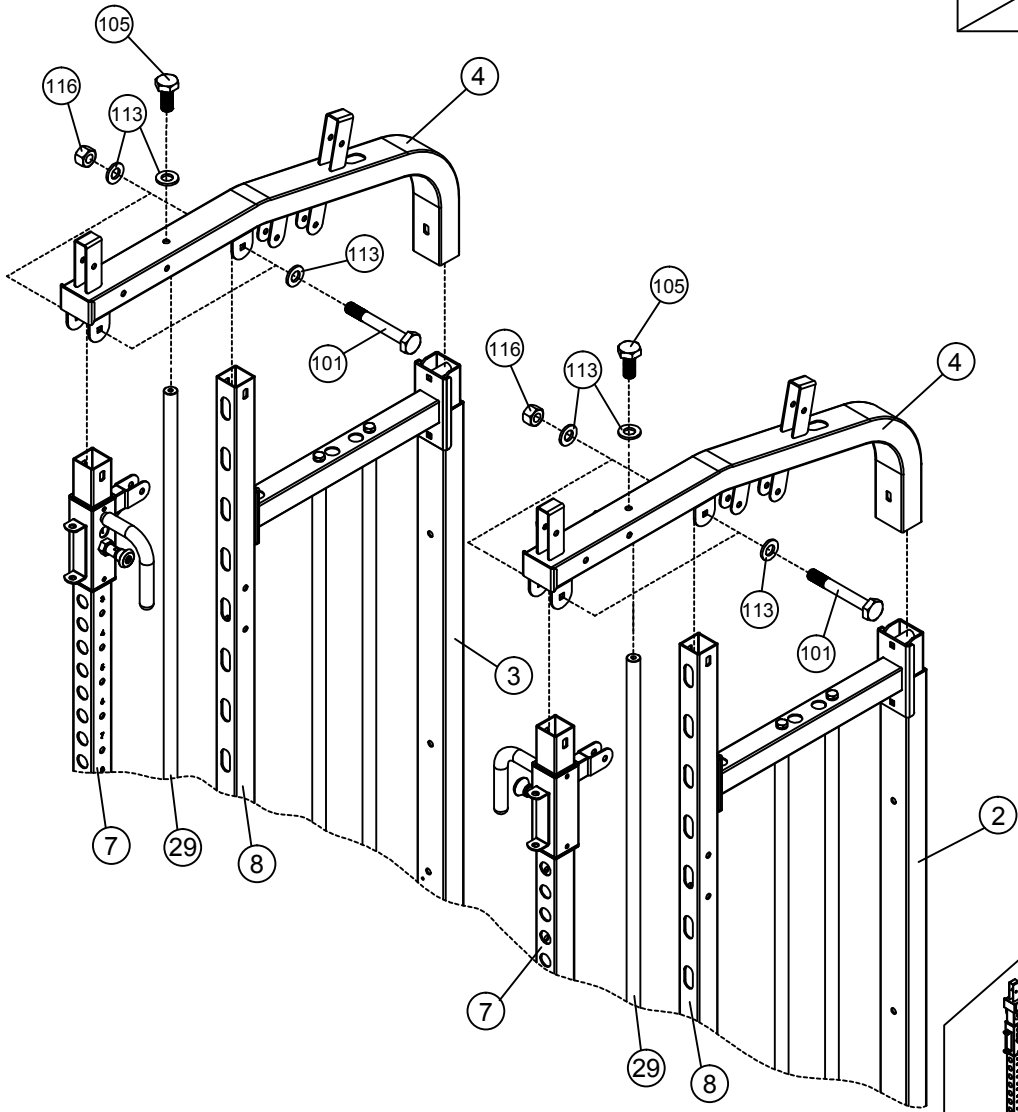
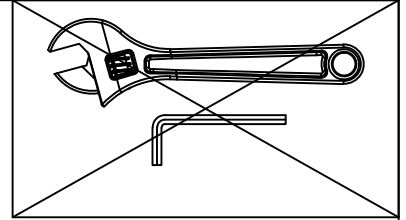

- |       |   |    |           |       |   |     |     |
|-------|---|----|-----------|-------|---|-----|-----|
| (101) |  | x4 | M10x 75mm | (113) |  | x10 | Φ10 |
| (105) |  | x2 | M10x 25mm | (116) |  | x4  | M10 |



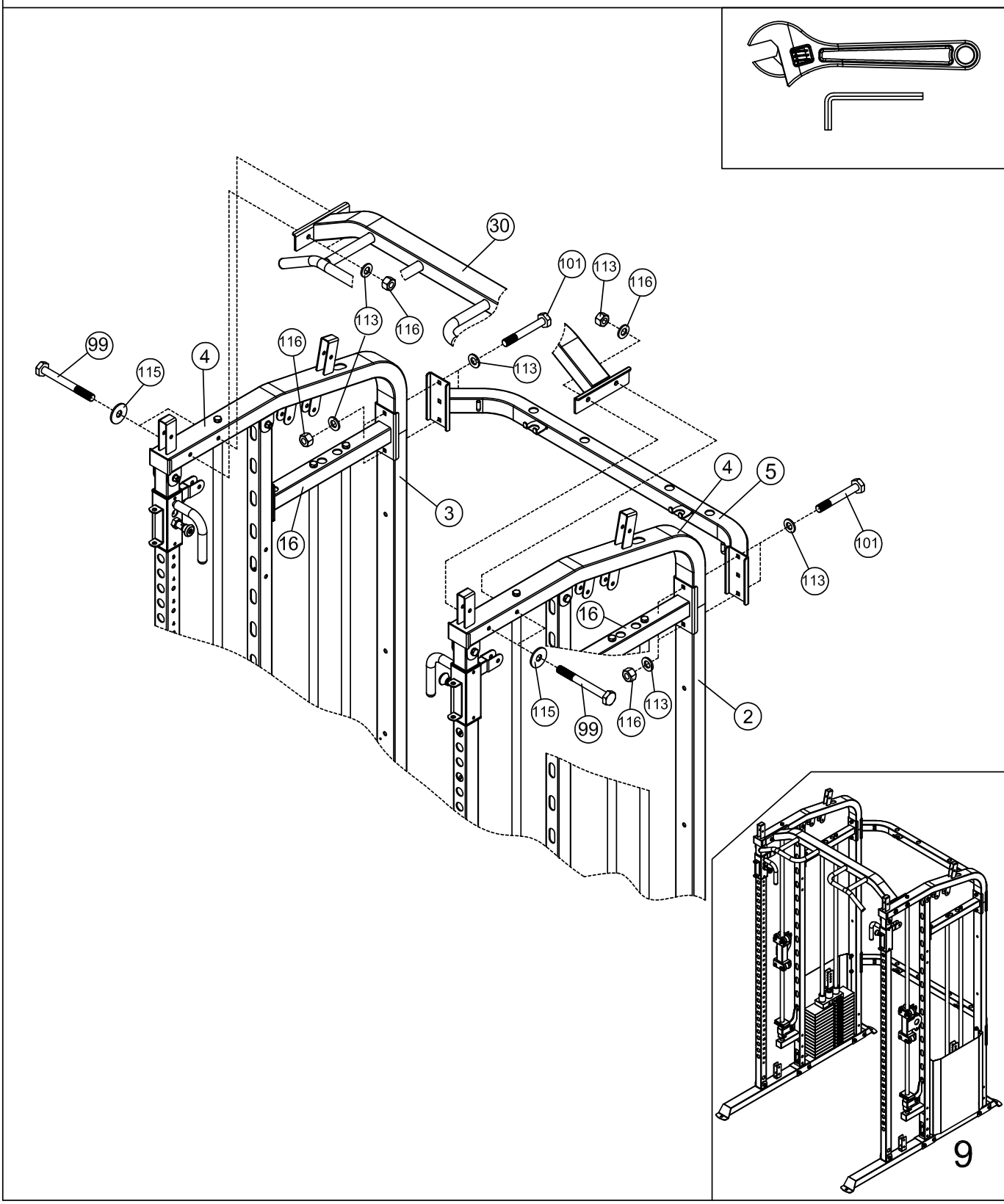
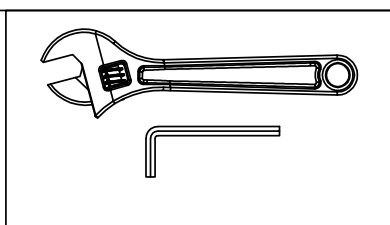

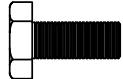
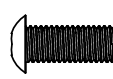
- 99  x4 M10x 90mm
- 101  x4 M10x 75mm
- 113  x12  $\Phi 10$
- 116  x8 M10
- 115  x4  $\Phi 30 \times \Phi 10.5$

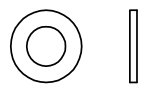
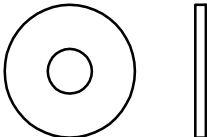

- |     |   |    |           |     |   |    |           |
|-----|---|----|-----------|-----|---|----|-----------|
| 105 |  | x4 | M10x 25mm | 117 |  | x2 | M10x 25mm |
| 96  |  | x4 | M8x 20mm  | 113 |  | x8 | Φ10       |
| 95  |  | x2 | Φ37xΦ13.5 | 116 |  | x4 | M10       |

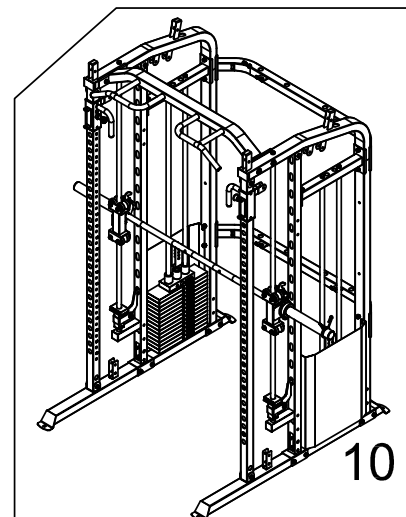
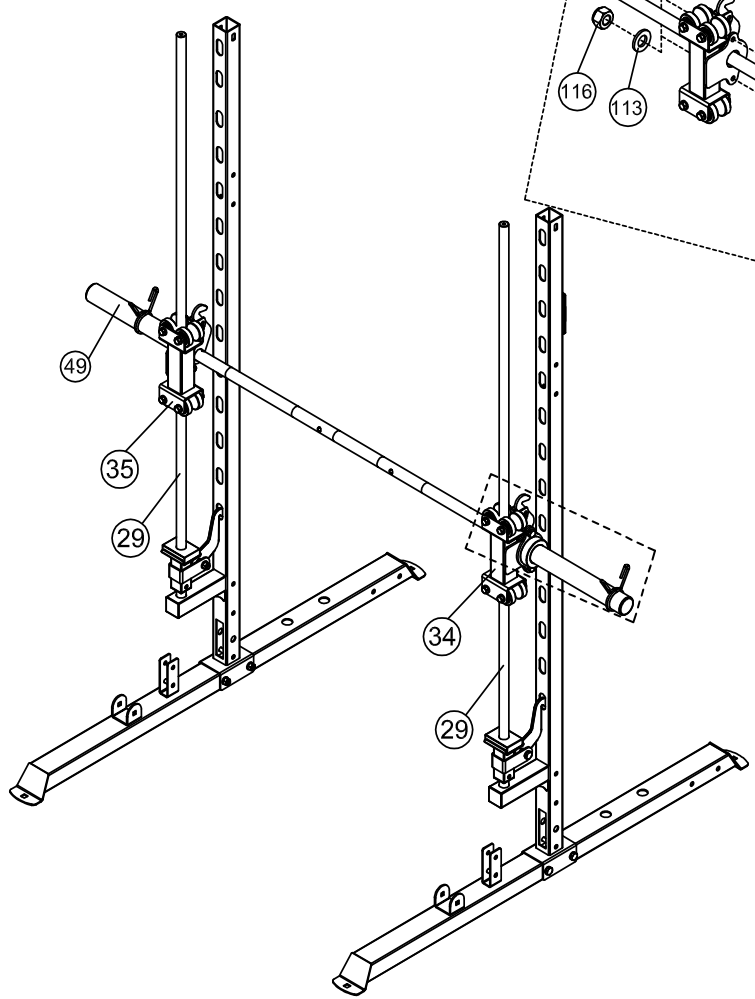
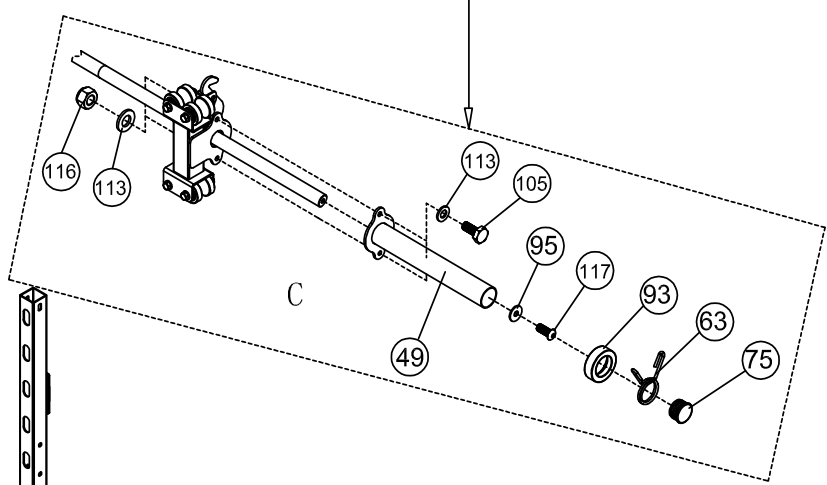
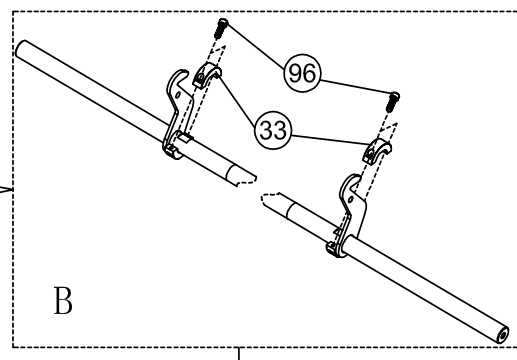
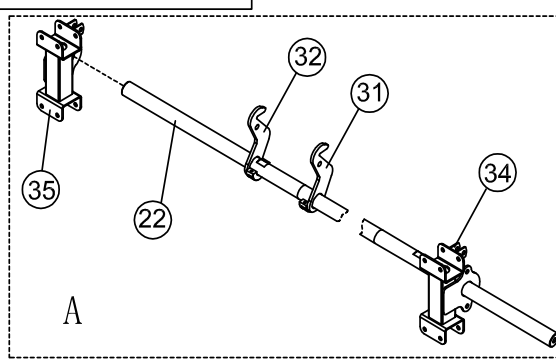
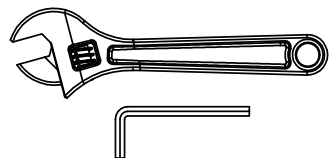

- |     |  |     |            |     |  |     |      |
|-----|--|-----|------------|-----|--|-----|------|
| 97  |  | ×2  | M12× 135mm | 113 |  | ×40 | Φ10  |
| 102 |  | ×2  | M10× 70mm  | 114 |  | ×4  | Φ12  |
| 104 |  | ×18 | M10× 45mm  | 116 |  | ×20 | M10  |
| 64  |  | ×2  | M12        | 18  |  | ×2  | 8020 |

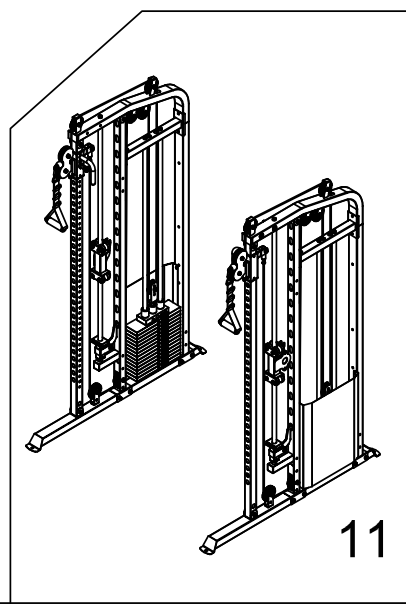
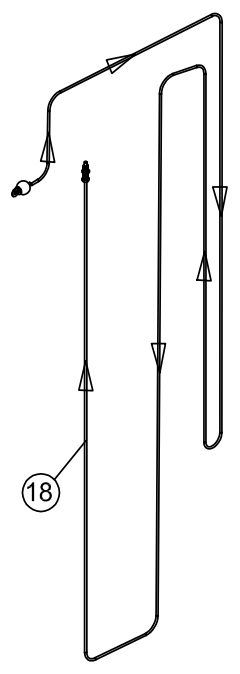
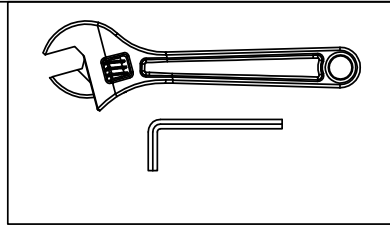
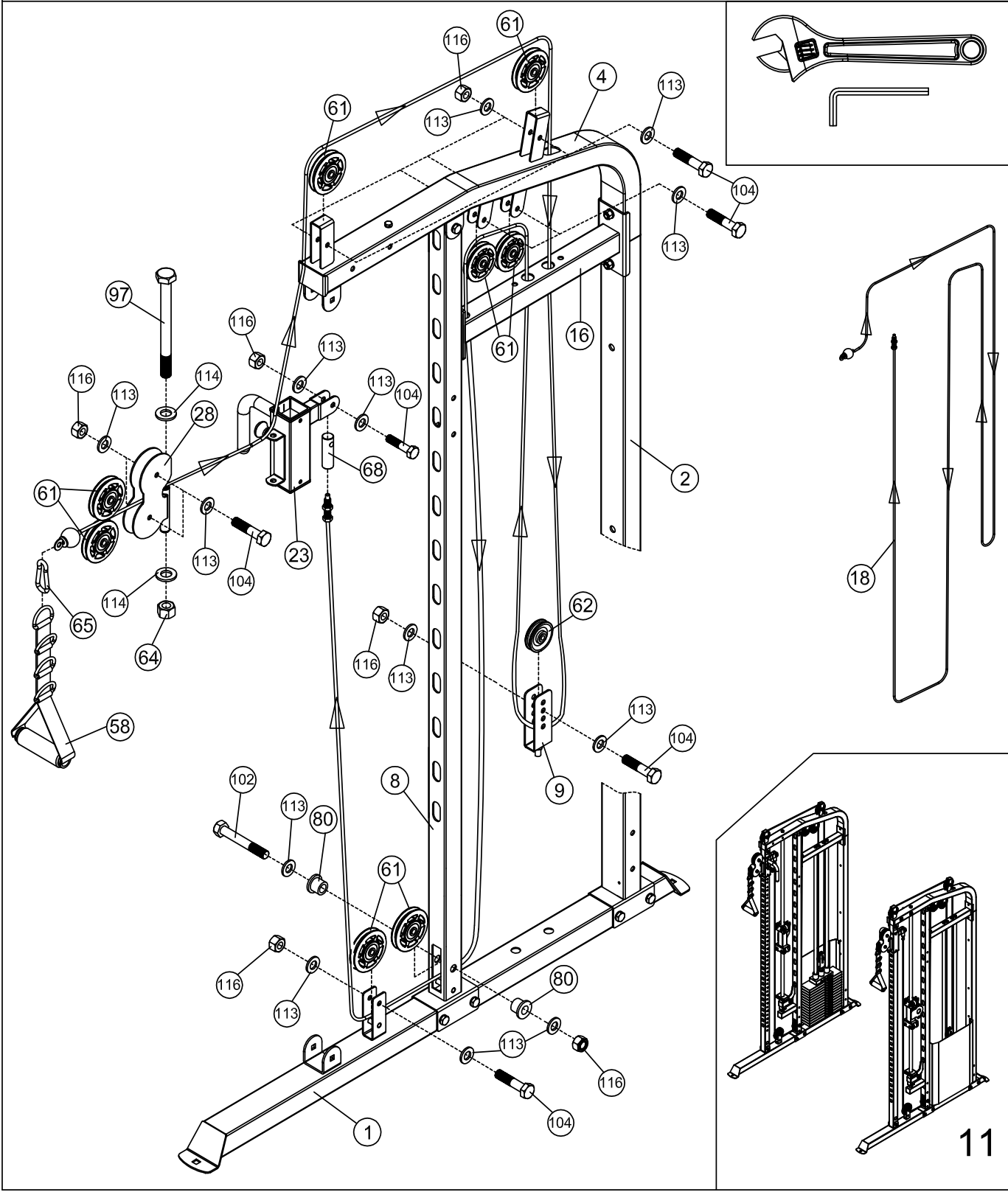

- |     |   |    |           |     |   |   |    |     |
|-----|---|----|-----------|-----|---|---|----|-----|
| 99  |  | x2 | M10x 90mm | 113 |  |  | x4 | Φ10 |
| 98  |  | x1 | M12x 90mm | 114 |  |  | x2 | Φ12 |
| 109 |  | x2 | M8 x 35mm | 116 |  |  | x2 | M10 |
| 64  |  | x1 | M12       |     |   |   |    |     |

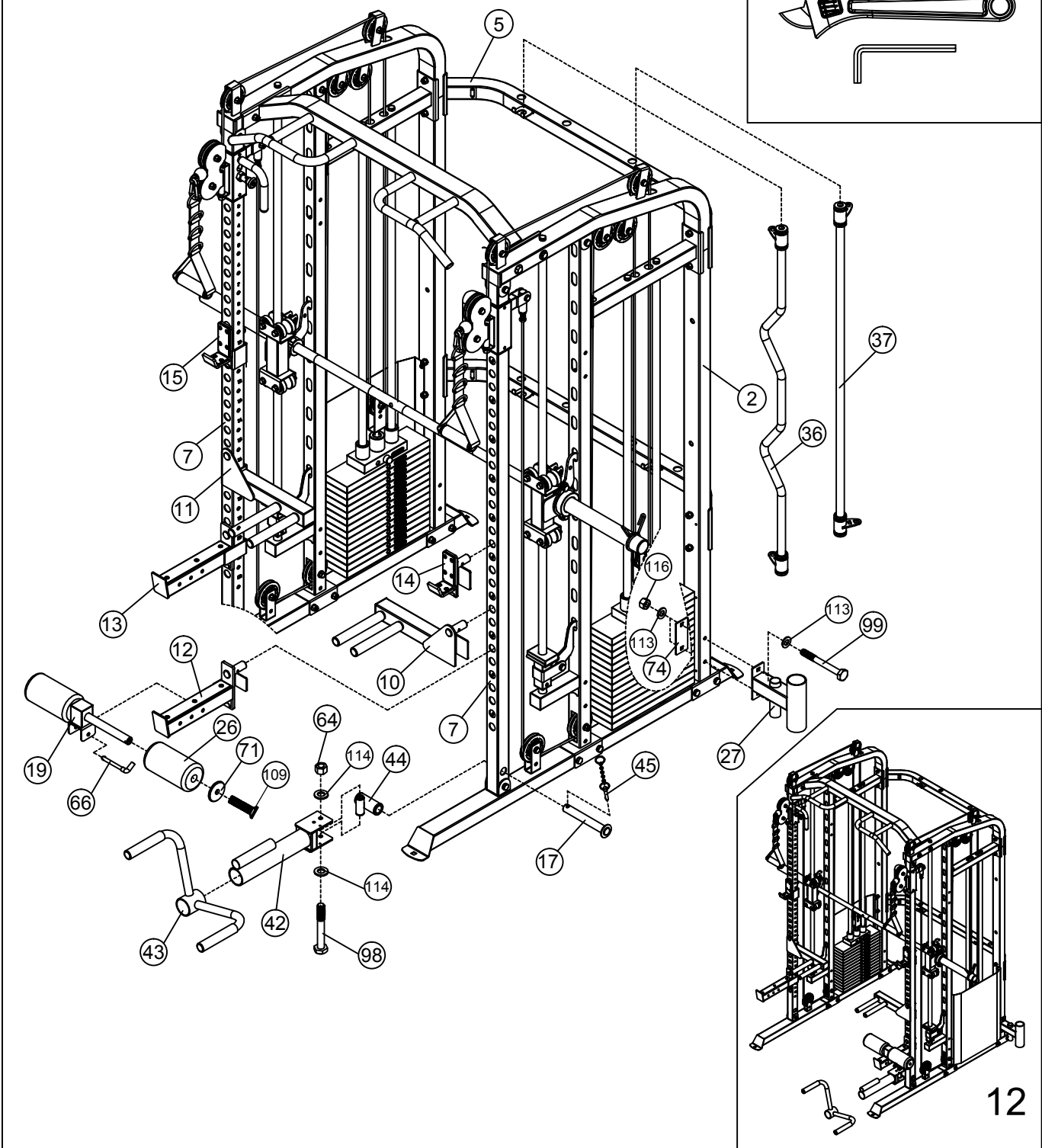
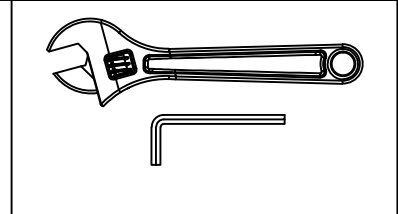

105

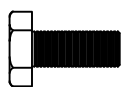

x6 M10x 25mm

113



x6 Φ10

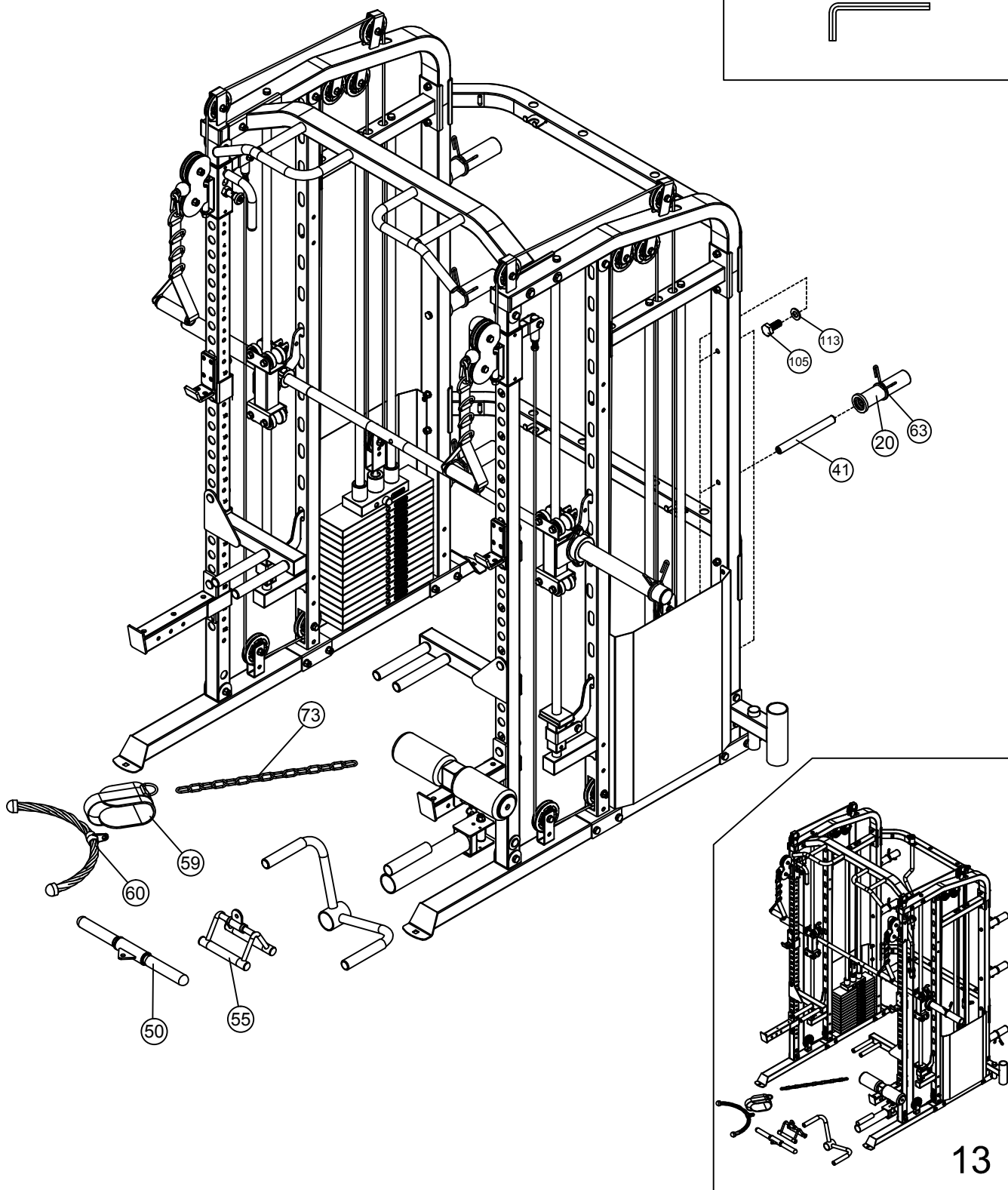
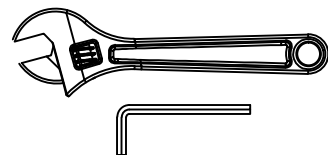

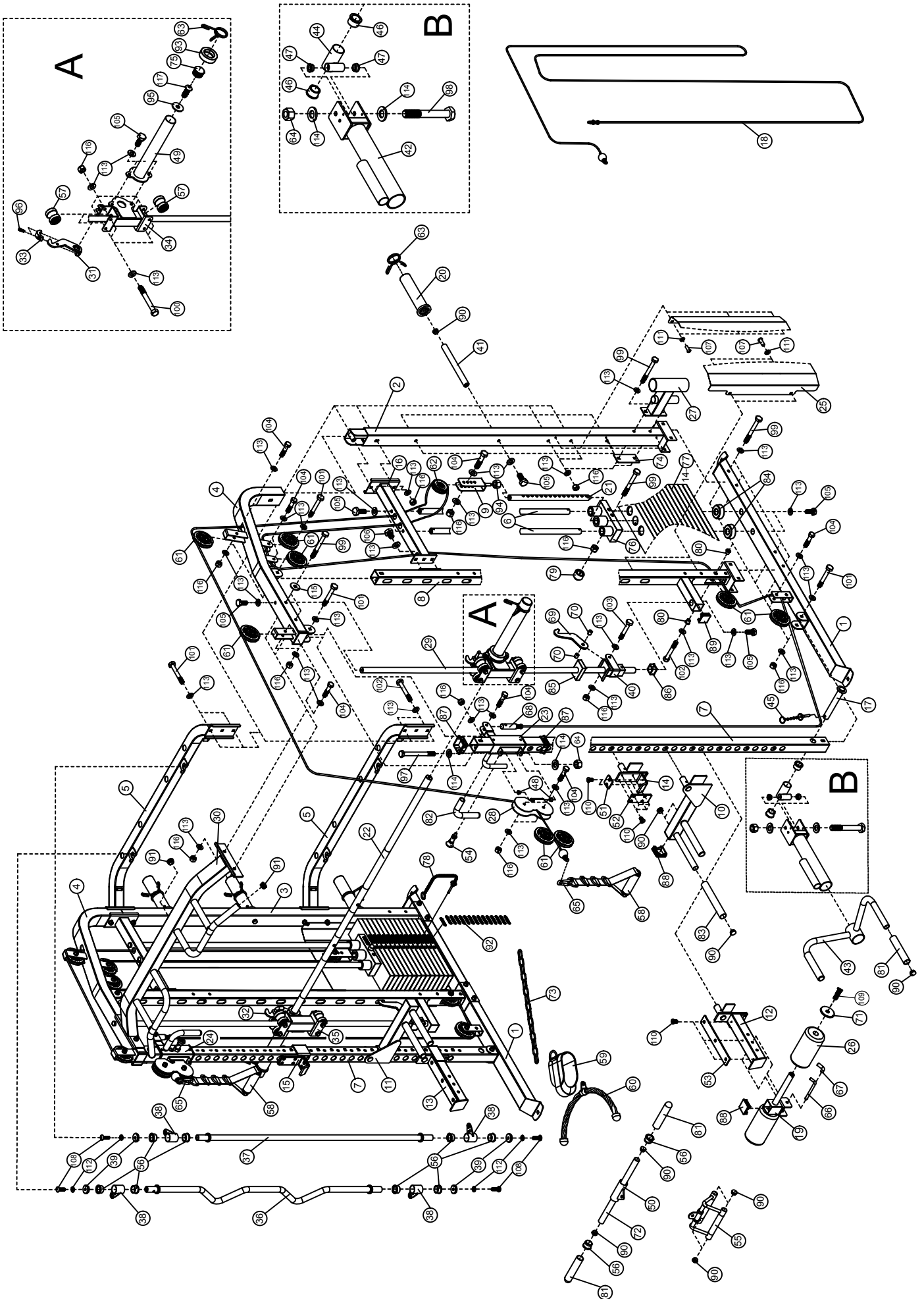

## LISTA CZĘŚCI

CZĘŚĆ NR	OPIS	ROZMIAR	ILOŚĆ
1	Rama podstawowa		2
2	Słupek tylny L		1
3	Słupek tylny p		1
4	Rama górna		2
5	Rama łącząca tylna		2
6	Drażek prowadzący tylny	φ25×1712	4
7	Trzon przedniej prowadnicy	□50×3×1950	2
8	Stojak pośredni		2
9	Grupa krążka z otworami		2
10	Drażek do pompek L		1
11	Drażek do pompek P		1
12	Długi stojak zabezpieczający L		1
13	Długi stojak zabezpieczający P		1
14	Krótki stojak zabezpieczający L		1
15	Krótki stojak zabezpieczający P		1
16	Rama łącząca		2
17	Drażek obrotowy	φ25×183	1
18	Podwójna linka	L=8020mm	2
19	Rama piankowa		1
20	Krótka osłona sztangi		6
21	Drażek wyboru		2
22	Drażek obciążenia	φ30×1865	1
23	Suwnica ramy L		1
24	Suwnica ramy P		1
25	Oslona		2
26	PIANKA	φ95×φ22×180	2
27	Gniazdo na sztangi		1
28	Oslona krążka		2
29	Drażek prowadzący	φ25×1770	2
30	Drażek poziomy		2
31	Gryf wiszący L		1
32	Gryf wiszący P		1
33	Półokrągłe mocowanie stałe		2
34	Stojak wałka L		1
35	Stojak wałka P		1
36	Drażek łamany (akcesorium)		1
37	Drażek prosty (akcesorium)		1
38	Piasta		4
39	Zaślepka drążka	φ38×φ9×8	4
40	Wspornik haka zabezpieczającego		2
41	Drażek ciężaru	φ25×245	6
42	Rama obrotowa		1
43	Rączka		1
44	Element dystansowy		1
45	Bolec		1
46	Tuleja	φ38×φ34×φ25×22	2
47	Tuleja	φ25×φ21.8×φ12.2×8	2
48	Tuleja	φ19×φ16×φ12×8	4
49	Długi rękaw na stojak na sztangę	φ50×350	2
50	Rama małego uchwytu		1

## LISTA CZĘŚCI

CZĘŚĆ NR	OPIS	ROZMIAR	ILOŚĆ
51	Podkładka stojaka	52×45×5	2
52	Podkładka stojaka	110×52×5	2
53	Podkładka stojaka	280×45×5	2
54	Ruchomy bolec blokujący		2
55	V-kształtna rączka		1
56	Tuleja	φ38×φ34×φ27×26	10
57	Zespół wałka		8
58	Nylonowy pasek do rączki		2
59	Pasek na kostkę	PH1300	1
60	Linka		1
61	Krażek z łożyskami	φ96	16
62	Mały krążek z łożyskami	φ75×25	2
63	Zacisk sprężynowy	φ49	8
64	Nakrętka	M12	3
65	Hak	φ8	2
66	Bolce sprężynowe L-kształtne	φ10×115	1
67	Rękaw gumowy	φ13×φ9.5×58	1
68	Regulowana oś	φ25×75	2
69	Hak zabezpieczający	R25×φ11×6	2
70	Element dystansowy	φ16×φ11×16	4
71	Płytki	φ68×5	2
72	Rurka małego uchwytu	φ25×1.5×370	1
73	15- łańcuch łączący		1
74	Wspornik		1
75	Zaślepka prostokątna		2
76	Podstawa selektora		2
77	Płytki ciężaru		28
78	Bolec wyboru ciężaru		2
79	Łeb śruby		2
80	Ośłona krążka		4
81	Krótki uchwyt do pompek	φ23×150	4
82	Uchwyt do pompek	φ24×φ18×227	2
83	Uchwyt do pompek	φ23×200	4
84	Gumowy stoper	φ62×φ24.5×25	4
85	Gumowy stoper	80×56×20	2
86	Prowadnice wspornika haka zabezpieczającego	38×26×30×3	2
87	Prowadnica ślizgowa	□60×2.5×□50×25	4
88	Zaślepka prostokątna	□50	3
89	Zaślepka prostokątna	□45	2
90	Zaślepka prostokątna	φ25	22
91	Zaślepka prostokątna	φ28	6
92	Markery wyboru	51×13	2
93	Podkładka amortyzująca płytki ciężaru	φ78×φ47.5×23	2
94	Nakrętka sześciokątna	M12	2
95	Podkładka	φ37×φ13.5×3	2
96	Śruby z łbem walcowym	M8×20	4
97	Śruby z łbem sześciokątnym	M12×135	2
98	Śruby z łbem sześciokątnym	M12×90	1
99	Śruby z łbem sześciokątnym	M10×90	16
100	Śruby z łbem sześciokątnym	M10×85	8



## LISTA CZĘŚCI

CZĘŚĆ NR	OPIS	ROZMIAR	ILOŚĆ
101	Śruby z łbem sześciokątnym	M10×75	10
102	Śruby z łbem sześciokątnym	M10×70	6
103	Śruby z łbem sześciokątnym	M10×65	2
104	Śruby z łbem sześciokątnym	M10×45	18
105	Śruby z łbem sześciokątnym	M10×25	22
106	Śruby z łbem sześciokątnym	M10×15	4
107	Śruby samogwintujące	M6×16	10
108	Śruba imbusowa	M8×25	4
109	Śruba imbusowa	M8×35	2
110	Śruba z łbem sześciokątnym	M6×12	18
111	Podkładka	6	10
112	Podkładka	8	4
113	Podkładka	10	142
114	Podkładka	12	6
115	Podkładka	φ30×φ10.5×2.5	4
116	Nakrętka	M10	64
117	Śruba imbusowa	M10×25	2
	Klucz imbusowy	6#	1
	Klucz imbusowy	5#	1
	Klucz imbusowy	4#	1

**CAUTION!**

Read all precautions and instructions in this manual before using this equipment.

**BEFORE YOU BEGIN**

Thank you for selecting the Cyborg 1 HMS. For your safety and benefit, read this manual carefully before using the machine. As a manufacturer, we are committed to provide you complete customer satisfaction.

**IMPORTANT SAFETY NOTICE**

This product is intended only for home use and has been designed to ensure optimal safety. The following rules shall be obeyed:

1. Before starting your workout, consult your physician to check if there are any reasons preventing the use of this fitness equipment. The doctor's decision is required if you take medicines that affect your heart work, blood pressure and levels of cholesterol. It is also necessary in the case of persons aged over 35 and people with health problems.
2. Always do your warm-up before training.
3. During exercise and after its completion the training equipment should be protected from children and animals.
4. The equipment shall be placed on dry, stable and properly levelled surface. All sharp objects shall be removed from its direct vicinity. The equipment should be protected from humidity. Possible surface irregularities should be levelled. It is recommended to use special anti-slip base to prevent the equipment displacement during workout.
5. Free space should not be smaller than 0.6 m and greater. Pay attention to worrying signals. Incorrect or excessive exercising means health hazard. If headache or dizziness, chest pain, irregular heart rhythm or other worrying symptoms appear during training, the workout shall be stopped immediately and a doctor shall be consulted. Incorrect or over-intensive training can lead to traumas.
6. Check the training space available in directions of the equipment accessibility. Free space must also include space for emergency quitting. If different pieces of equipment are located side by side, the size of free space can be divided.
7. Before the first use, and later at regular intervals, tightness of all screws, bolts and other joints shall be checked.
8. Before starting your exercise, check fixing of parts and joints between them. Workout can be started only if the equipment is fully operational.
9. The equipment shall be regularly checked for wearing-out and damages. Only then will it fulfil safety requirements. Special attention shall be paid to foam grips, caps on legs and upholstery, which are all fast wearing parts. Damaged parts shall be immediately repaired or replaced. Until then, the training equipment cannot be used.
10. Do not put any elements into openings.
11. Pay attention to protruding adjustment devices and other structural elements that might hinder exercise.
12. The equipment can only be used according to its intended purpose. If any parts wears out or is damaged, or if you hear worrying sounds when using the equipment, you should immediately stop exercising. Do not use the equipment again until the problem is removed.
13. Wear comfortable clothes and sport shoes for training. Avoid loose clothes that might catch protruding parts of the equipment or limit your mobility.
14. The equipment falls into class H according to standard EN ISO 20957-1 and is intended for home use only. It cannot serve therapeutic, rehab or commercial purposes.
15. When lifting or moving the equipment, maintain correct posture to avoid spine injuries.
16. The product is intended for adults only. Keep children without supervision away from the equipment.
17. During installation, follow closely the attached manual instruction and use only such parts that have been included in the package. Before installation, check if all parts from the list are included in the package.

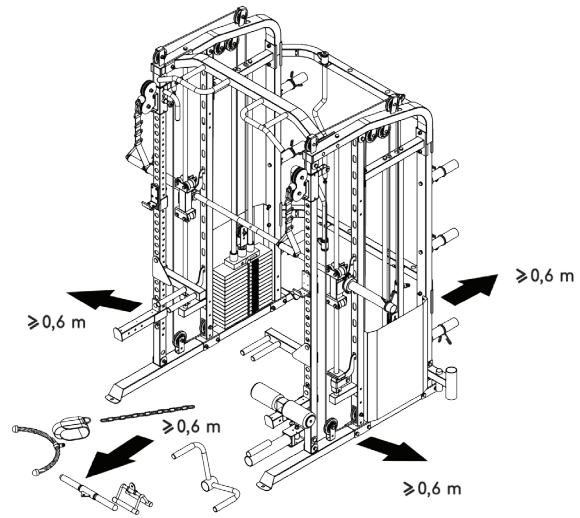

**WARNING:** READ THE INSTRUCTION BEFORE USING THE EQUIPMENT.

WE ARE NOT RESPONSIBLE FOR INJURIES OR DAMAGES TO OBJECTS CAUSED BY INCORRECT USE OF THE PRODUCT

**MAINTENANCE:** No aggressive cleaning agents shall be used to clean the equipment. Use a soft, wet cloth to remove dirt and dust. The equipment shall be kept in dry places and protected from humidity and corrosion.

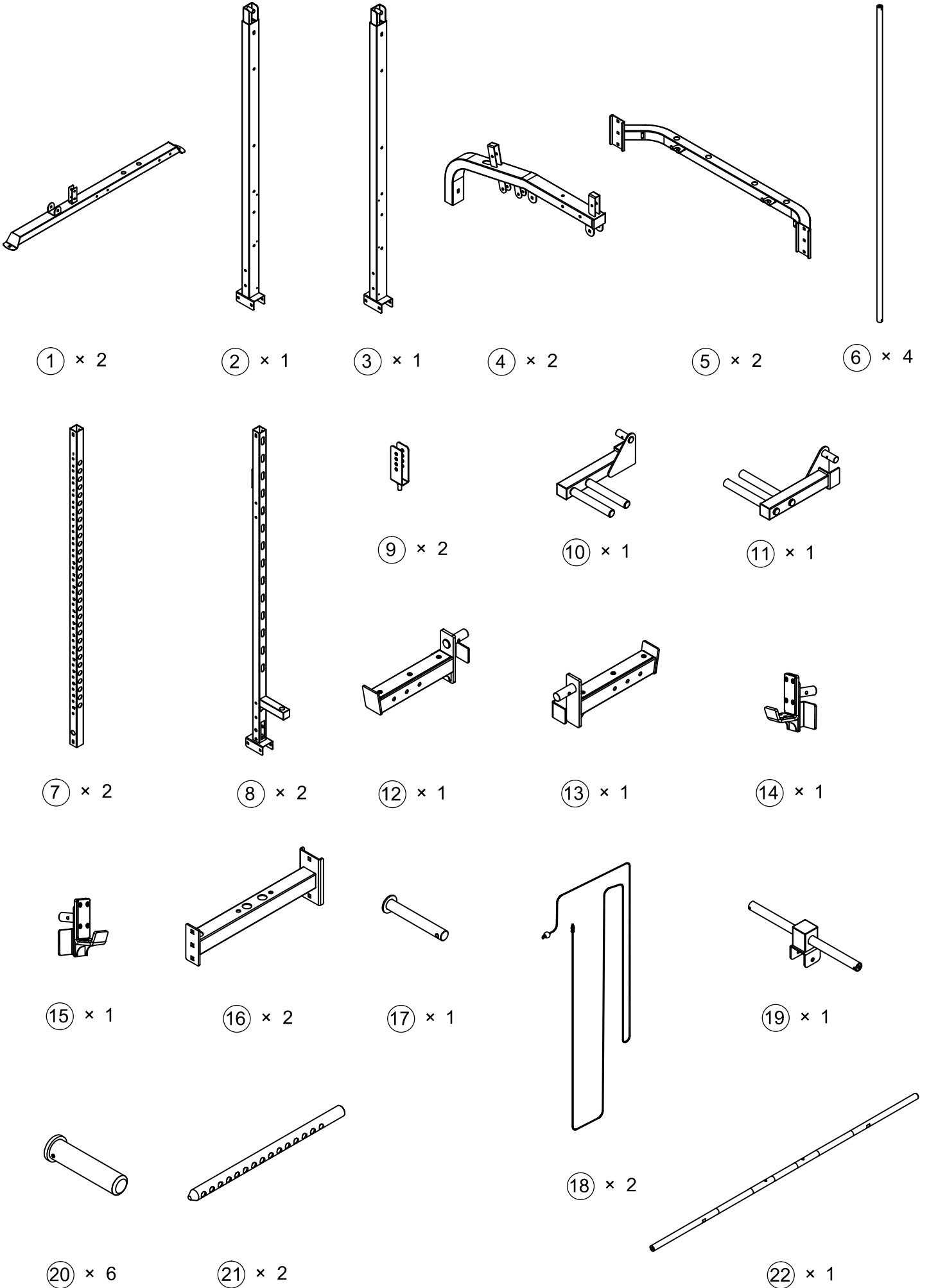

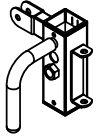

23 x 1

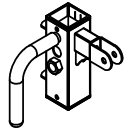

24 x 1

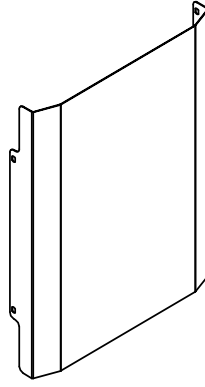

25 x 2

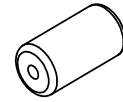

26 x 2

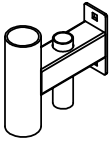

27 x 1



28 x 2

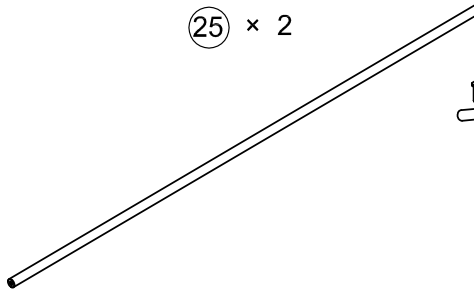

29 x 2

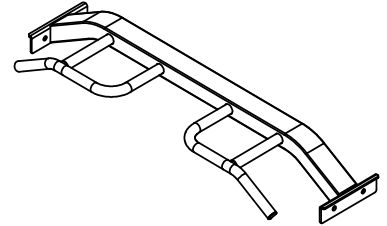

30 x 1



31 x 1



32 x 1



33 x 2

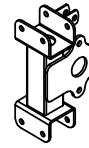

34 x 1



35 x 1

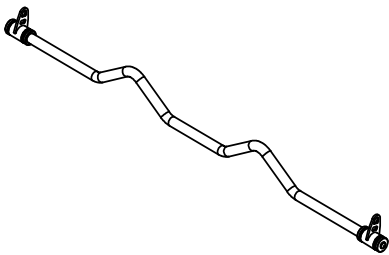

36 x 1

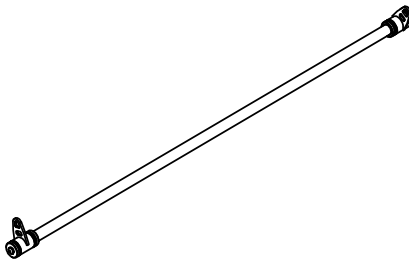

37 x 1

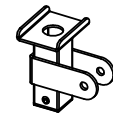

40 x 2

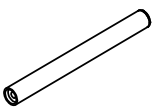

41 x 6



42 x 1

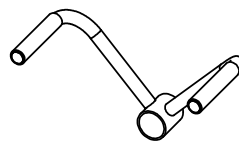

43 x 1

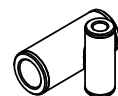

44 x 1

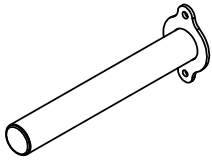

49 x 2

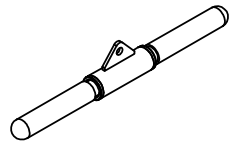

50 x 1



54 x 2

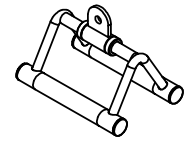

55 x 1



57 x 8

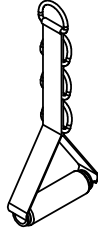

58 x 2



59 x 1

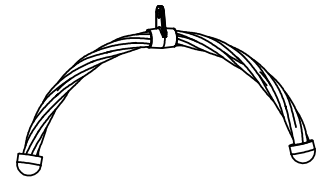

60 x 1



61 x 16



62 x 2

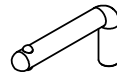

66 x 1



68 x 2



69 x 2



71 x 2



74 x 1



75 x 2

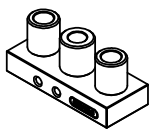

76 x 2

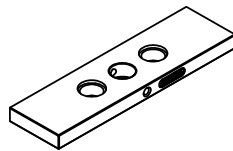

77 x 28

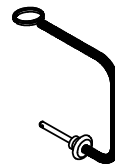

78 x 2



92 x 2



79 x 2



84 x 4



85 x 2



93 x 2

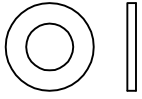

①①① × 10

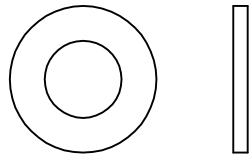

①①③ × 142

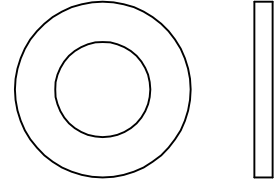

①①④ × 6

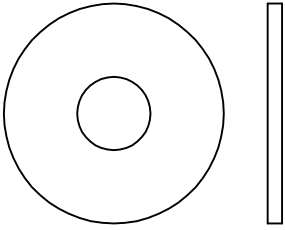

①①⑤ × 4

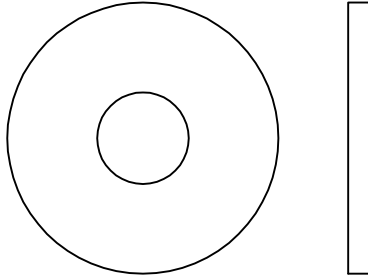

①①⑤ × 2

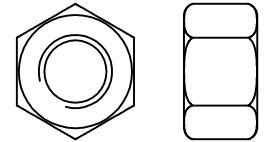

①①⑥ × 64

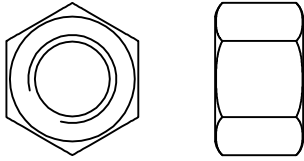

①①④ × 3

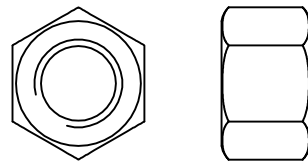

①①④ × 2

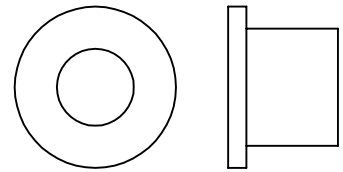

①①⑦ × 4

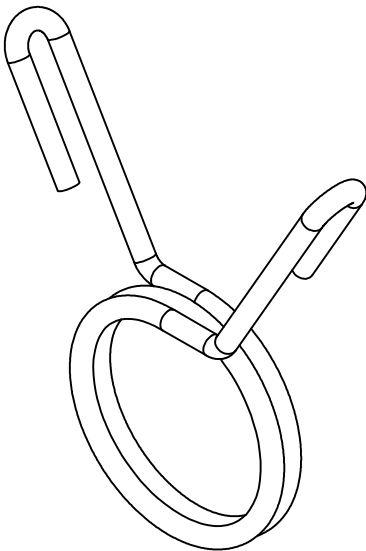

①①③ × 8

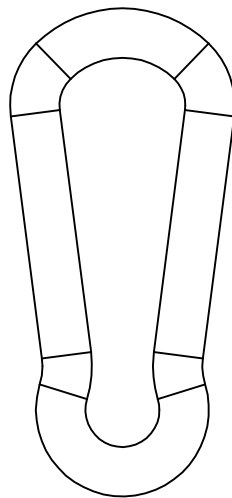

①①⑤ × 2

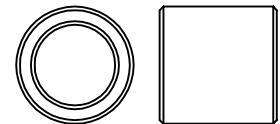

①①⑦ × 4

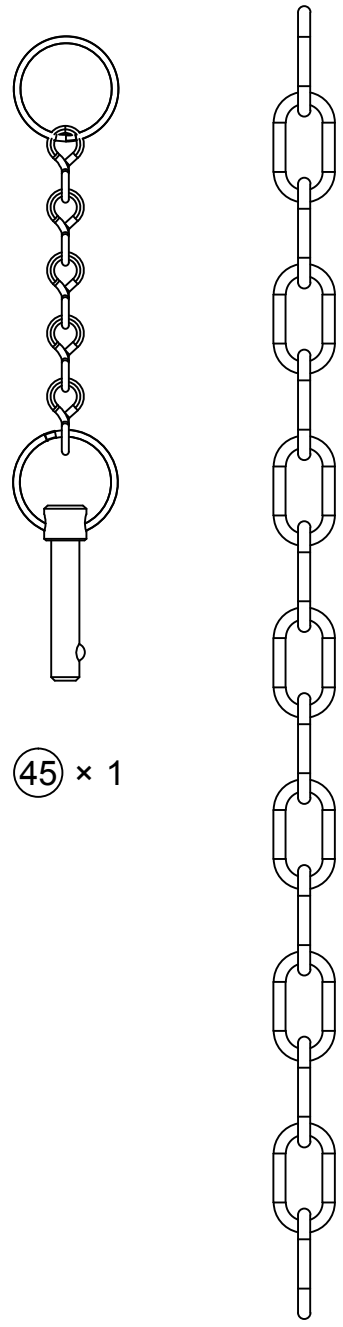
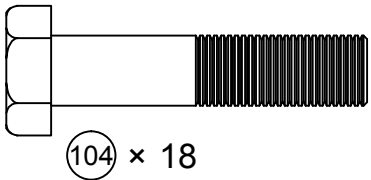
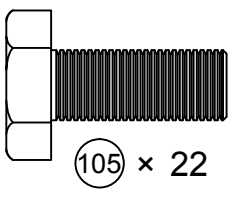
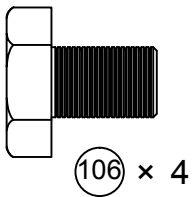
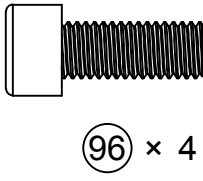
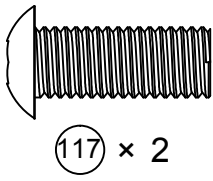
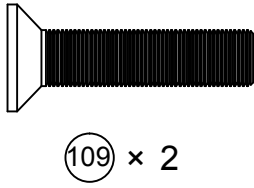
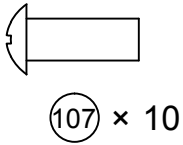

45 × 1

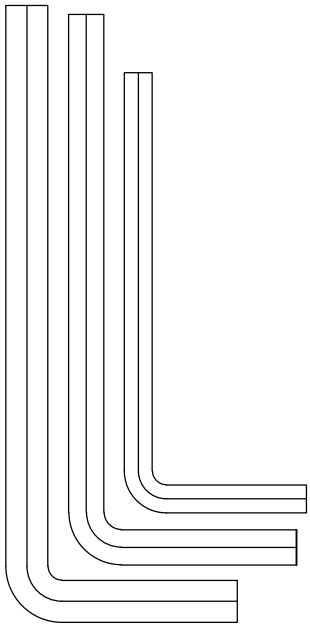



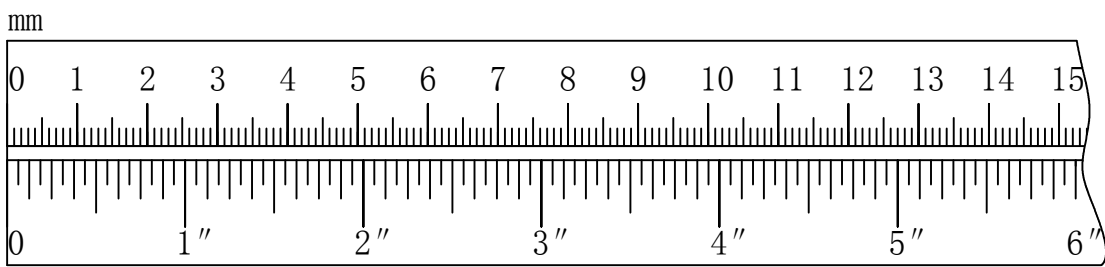

4# × 1  
5# × 1  
6# × 1

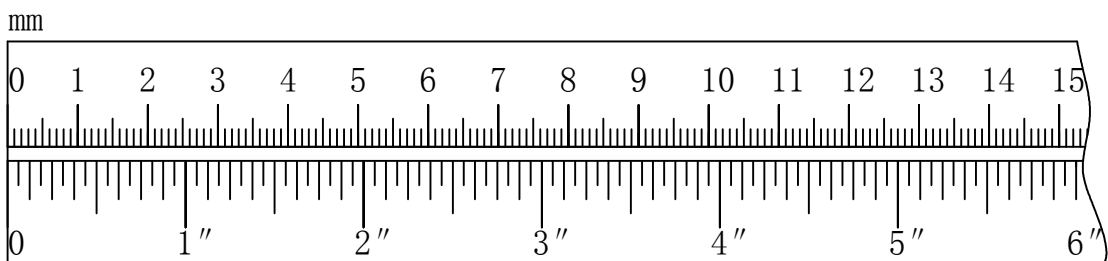
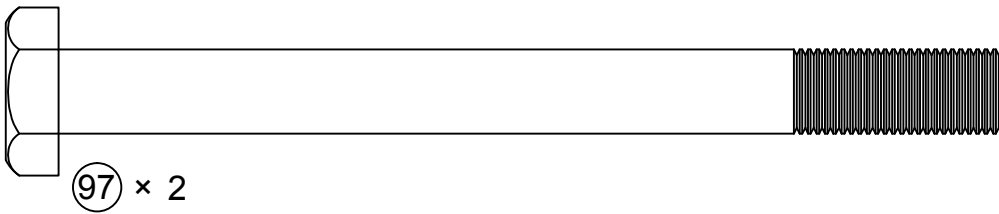
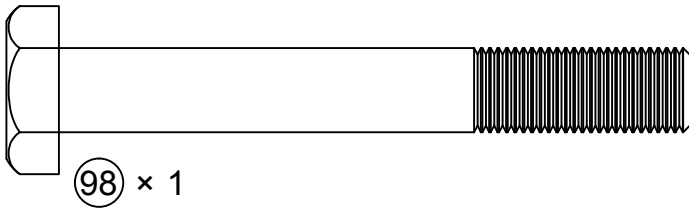
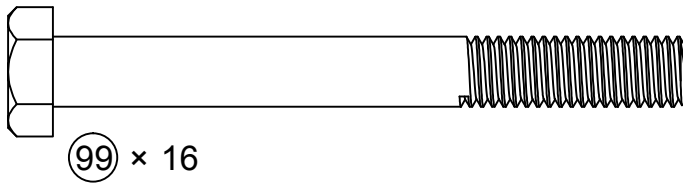
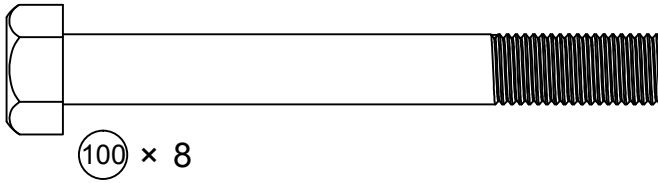
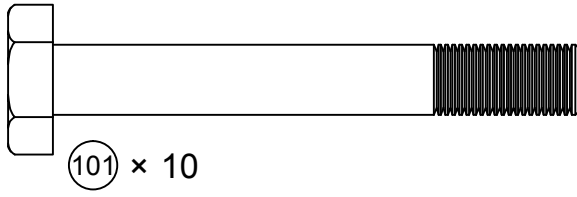
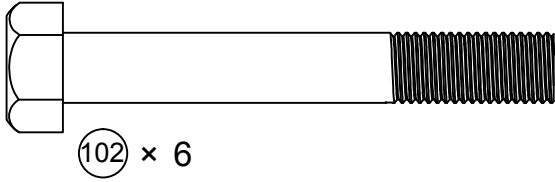
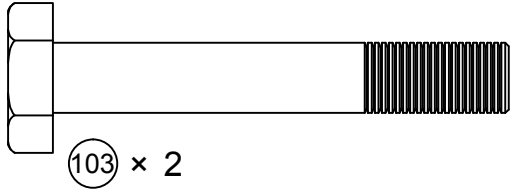
73 × 1



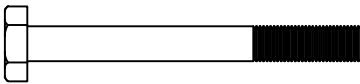





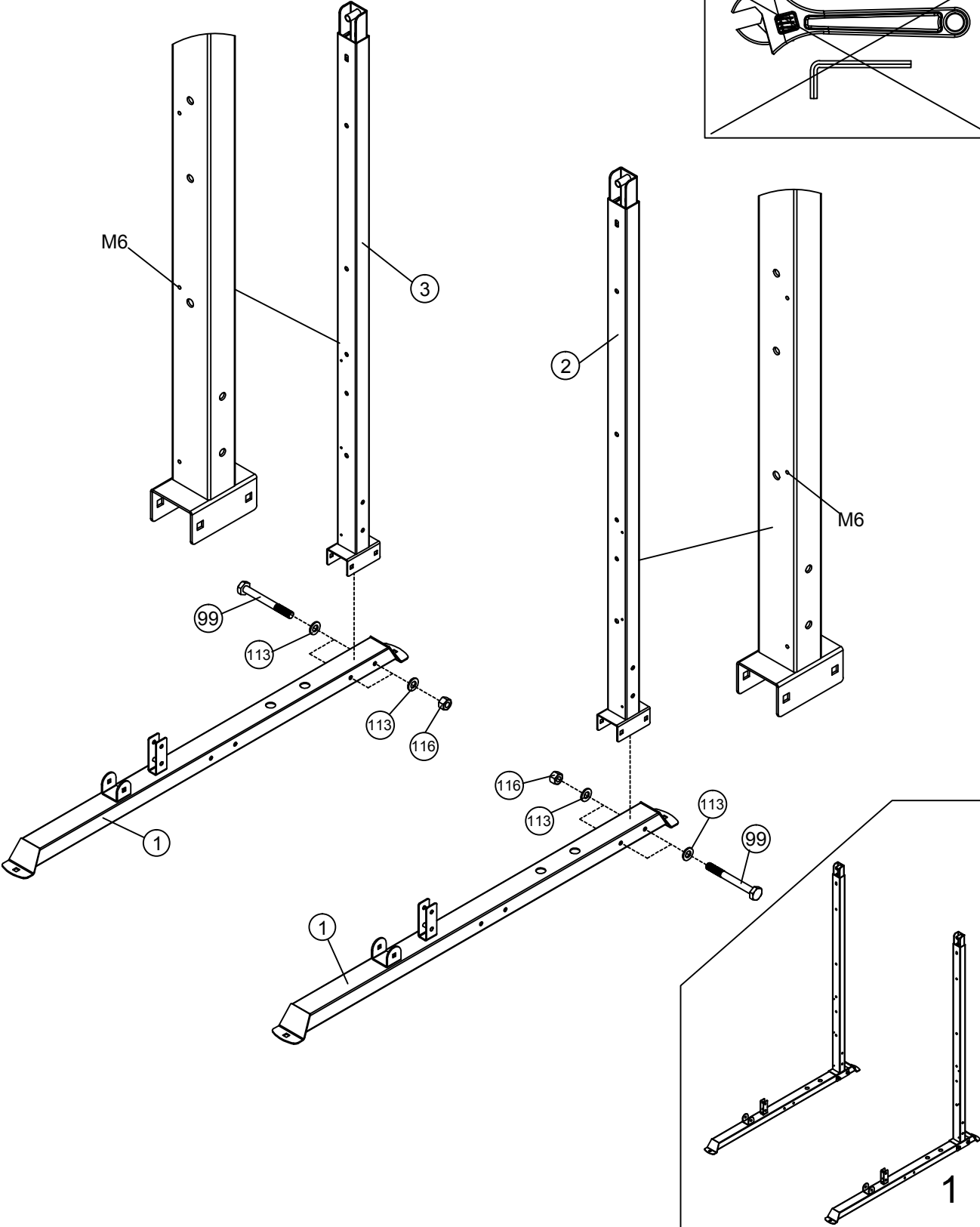
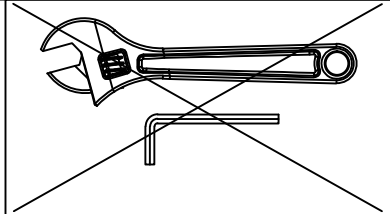

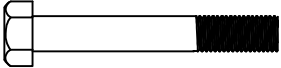

- 99  ×4 M10× 90mm
- 113   ×8 Φ10
- 116   ×4 M10

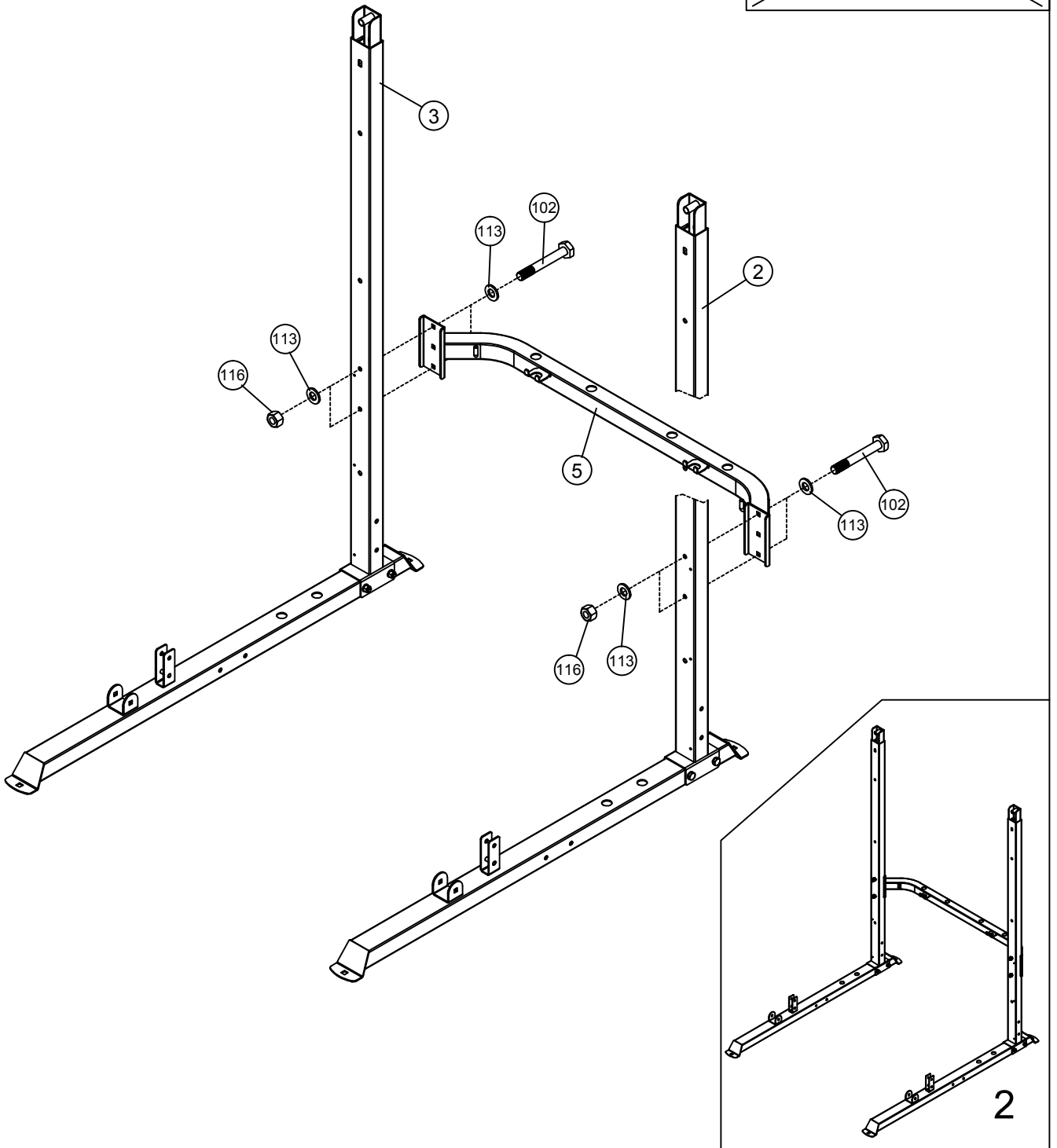
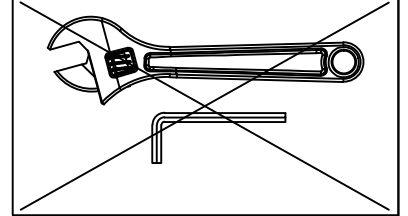

- |       |   |    |           |       |   |  |    |     |
|-------|---|----|-----------|-------|---|--|----|-----|
| (102) |  | ×4 | M10× 70mm | (113) |  |  | ×8 | Φ10 |
| (116) |  |    |           |       |    |  | ×4 | M10 |

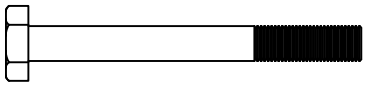
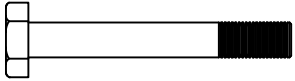



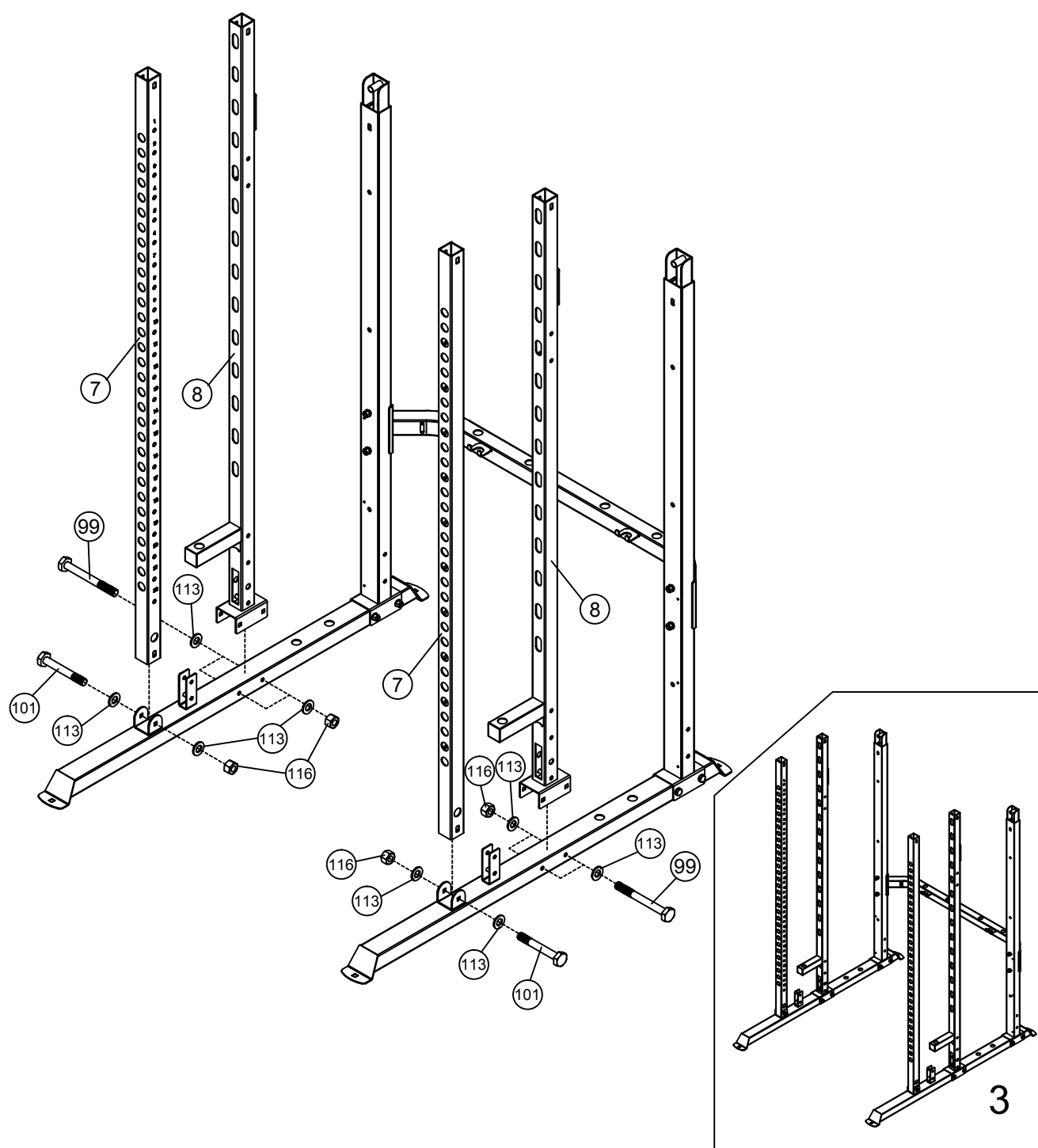
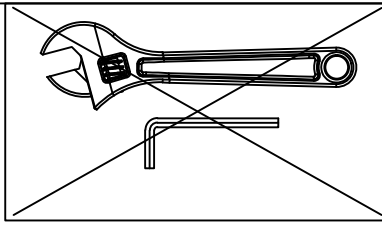

- 99  x4 M10x 90mm
- 101  x2 M10x 75mm
- 113  x12  $\Phi 10$
- 116  x6 M10



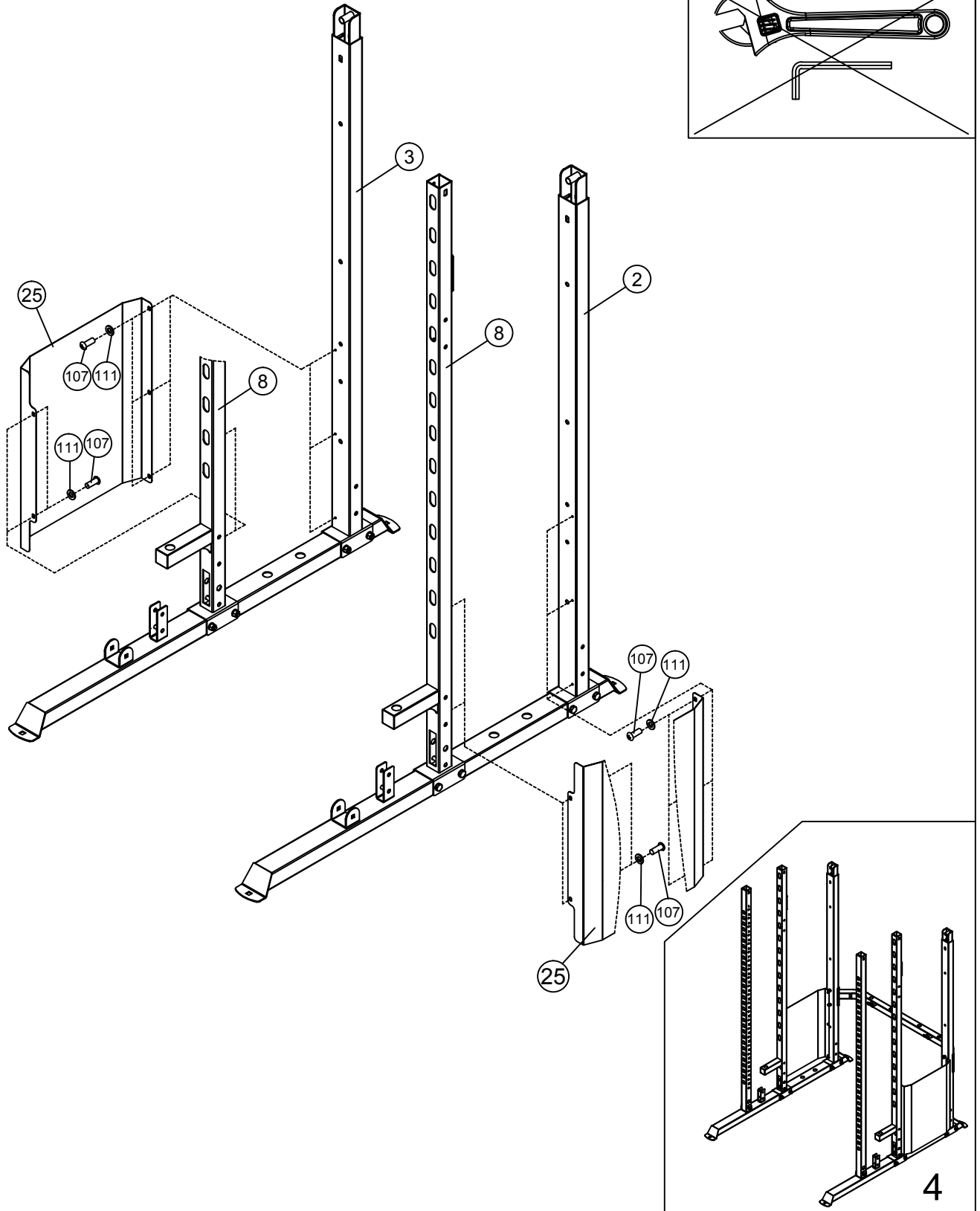
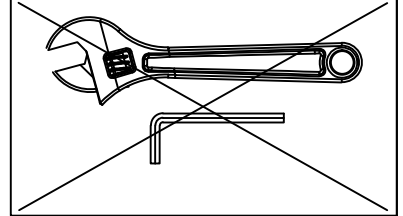

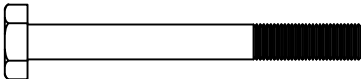

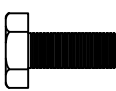
107  ×10 M6× 16mm

111  | ×10 Φ6

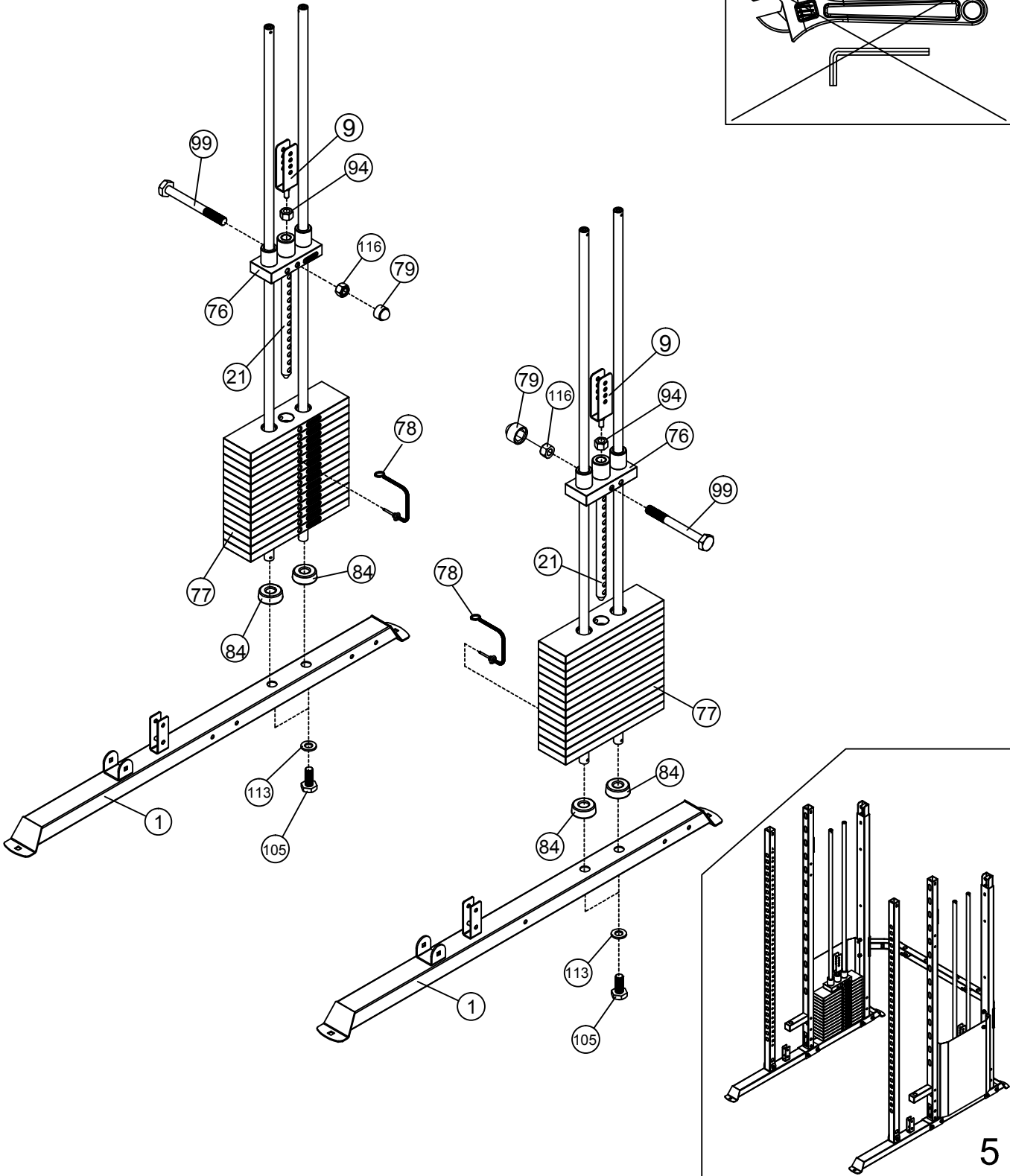
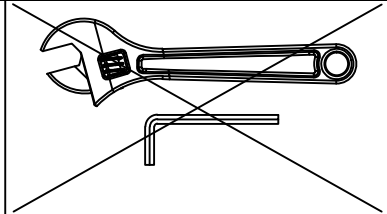

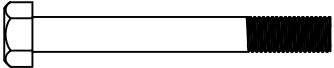
- |     |   |    |           |     |   |    |     |
|-----|---|----|-----------|-----|---|----|-----|
| 99  |  | ×2 | M10× 90mm | 113 |  | ×4 | Φ10 |
| 105 |  | ×4 | M10× 25mm | 116 |  | ×2 | M10 |
| 94  |  | ×2 | M12       |     |   |    |     |

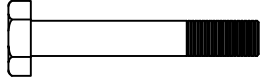

100		×8	M10× 100mm	113		×22	Φ10
103		×2	M10× 65mm	116		×10	M10
105		×2	M10× 25mm				

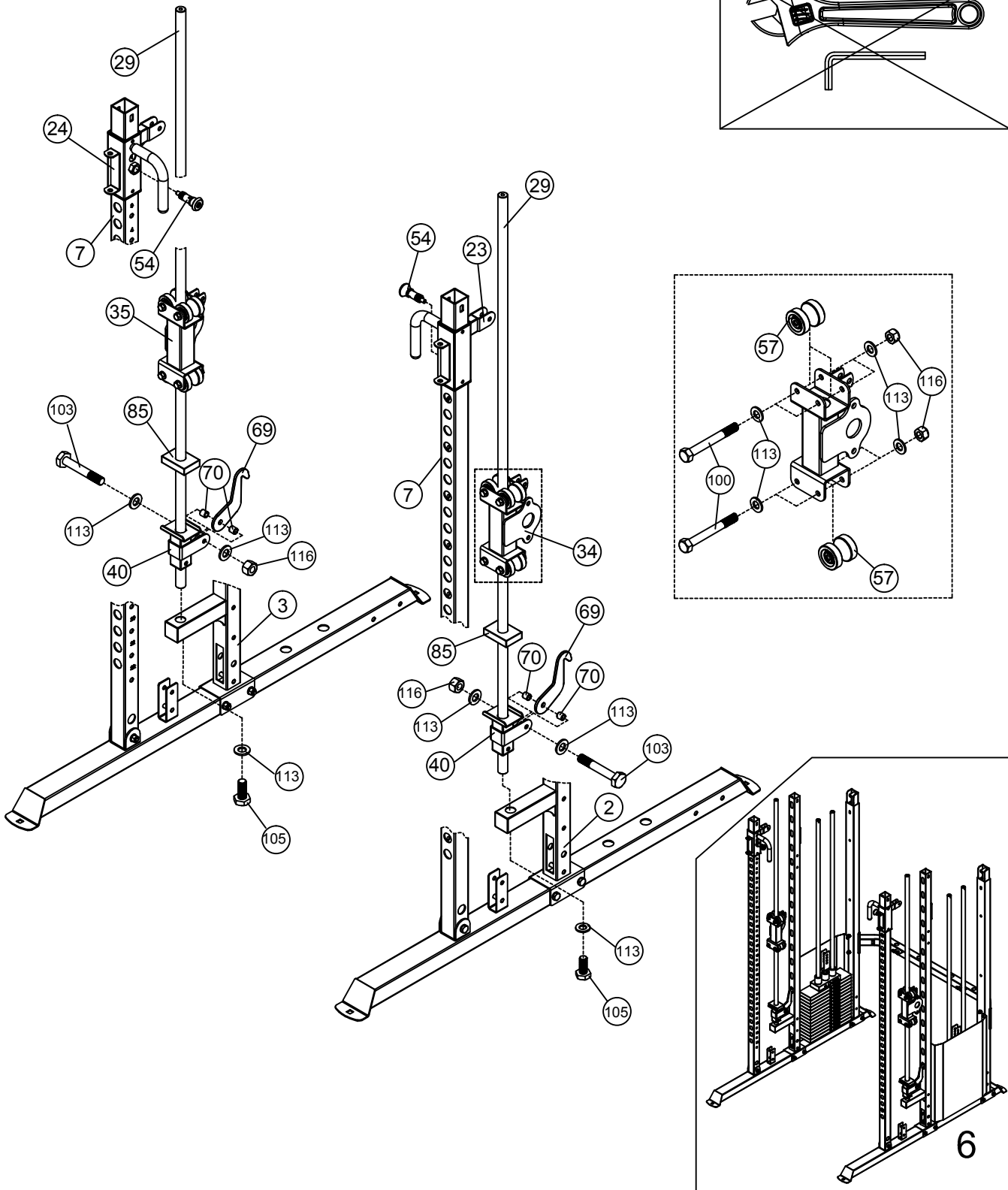
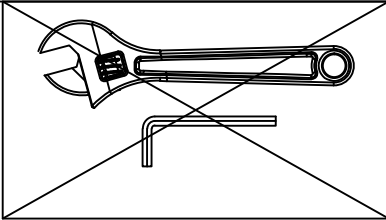

105

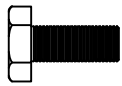

x4 M10 x 25mm

113







x8 Φ10

106

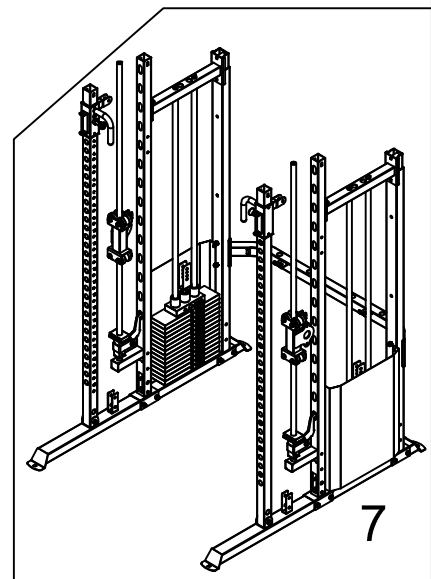
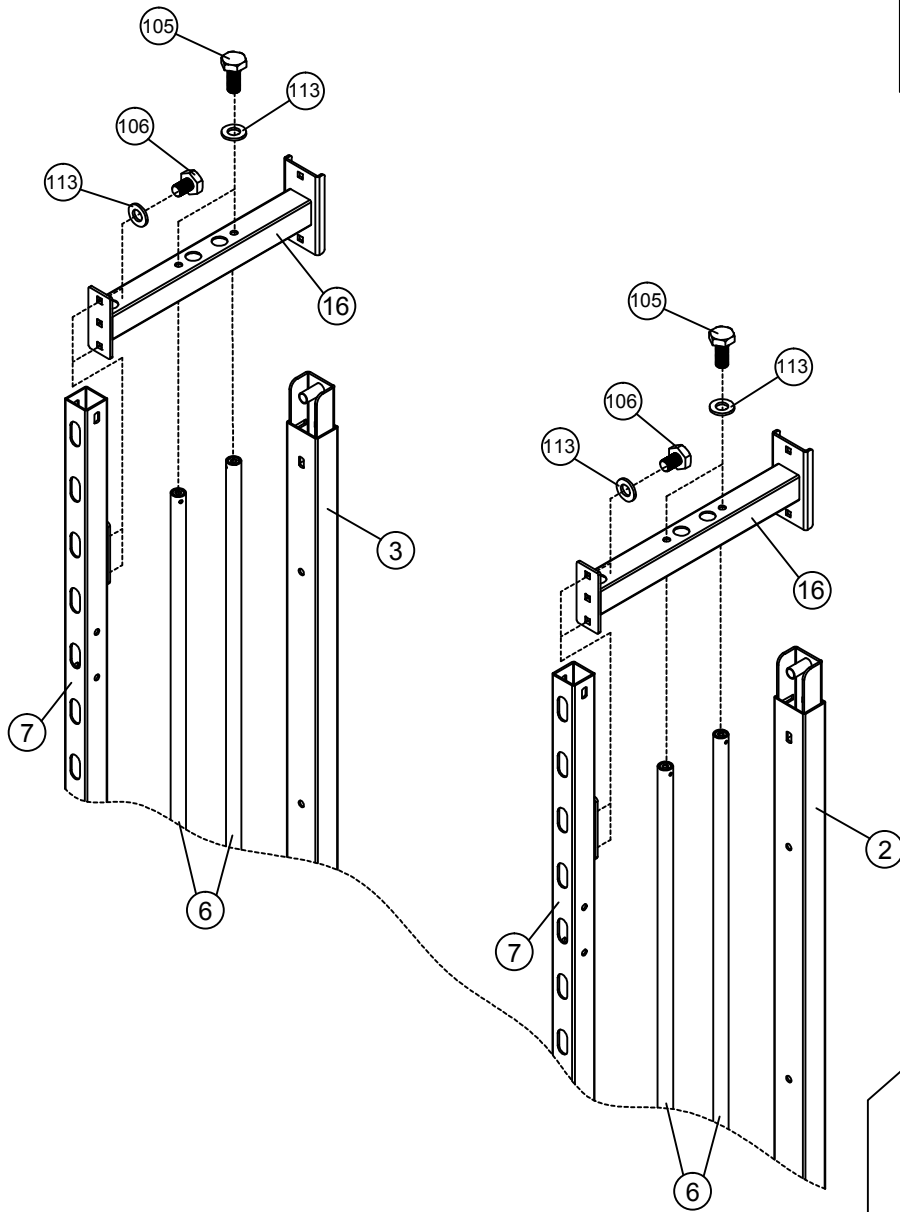
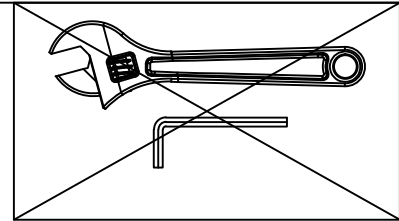

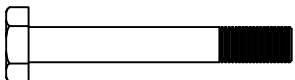

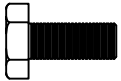

x4 M10 x 15mm

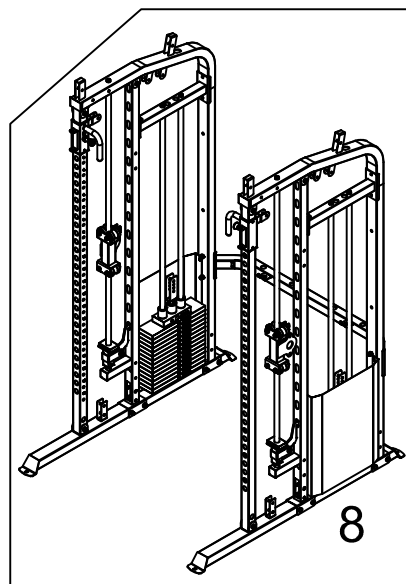
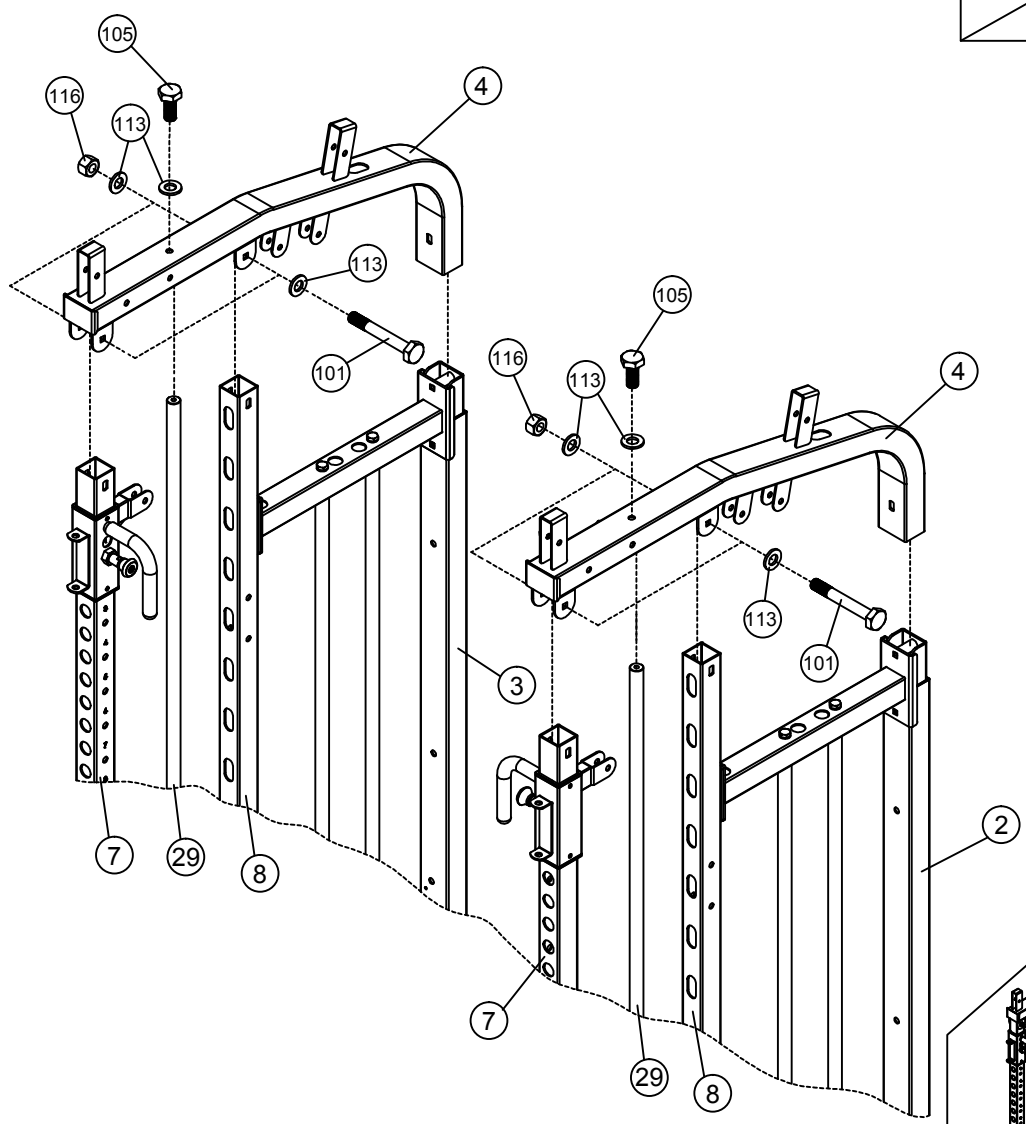
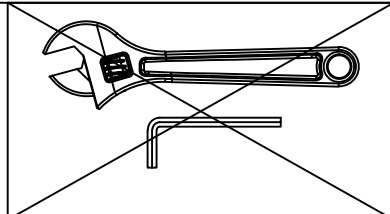

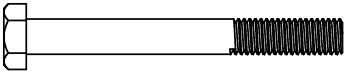

- |       |   |    |           |       |   |     |     |
|-------|---|----|-----------|-------|---|-----|-----|
| (101) |  | x4 | M10× 75mm | (113) |  | x10 | Φ10 |
| (105) |  | x2 | M10× 25mm | (116) |  | x4  | M10 |

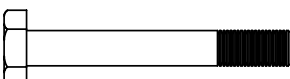

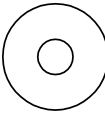

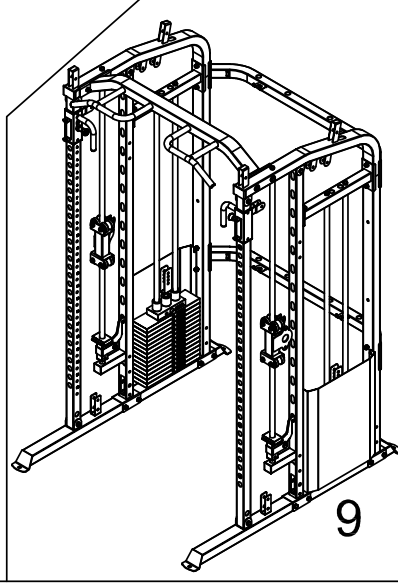
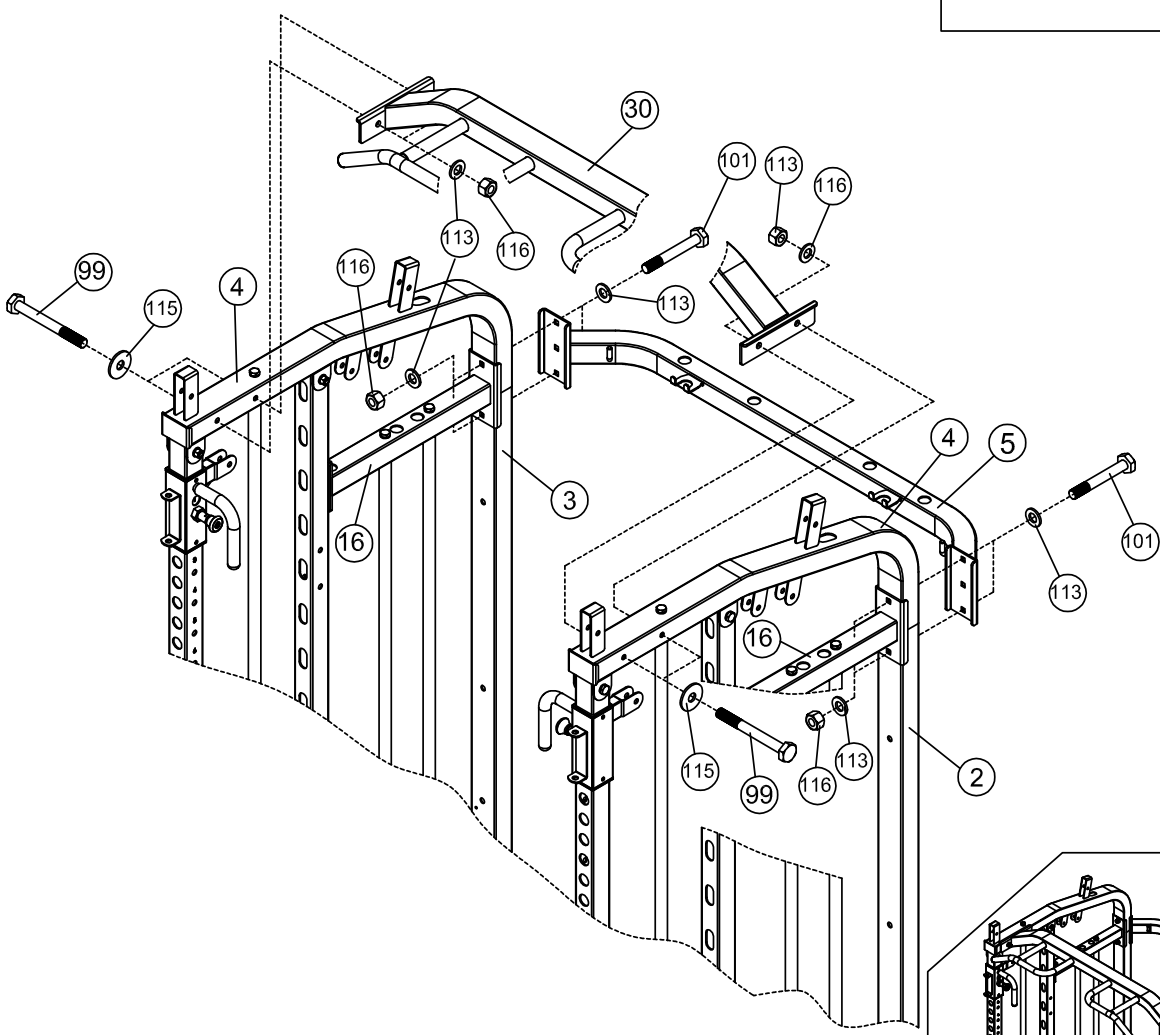
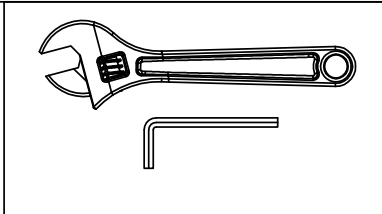

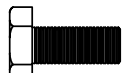

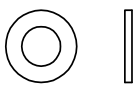
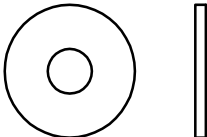
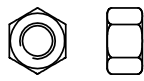

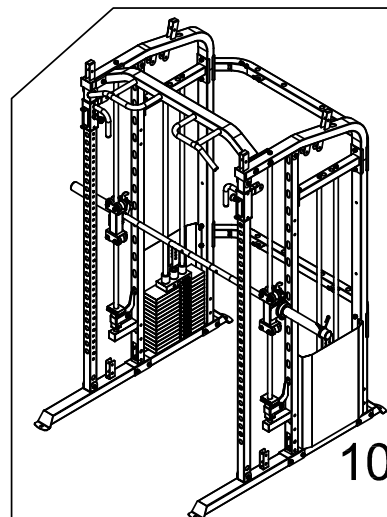
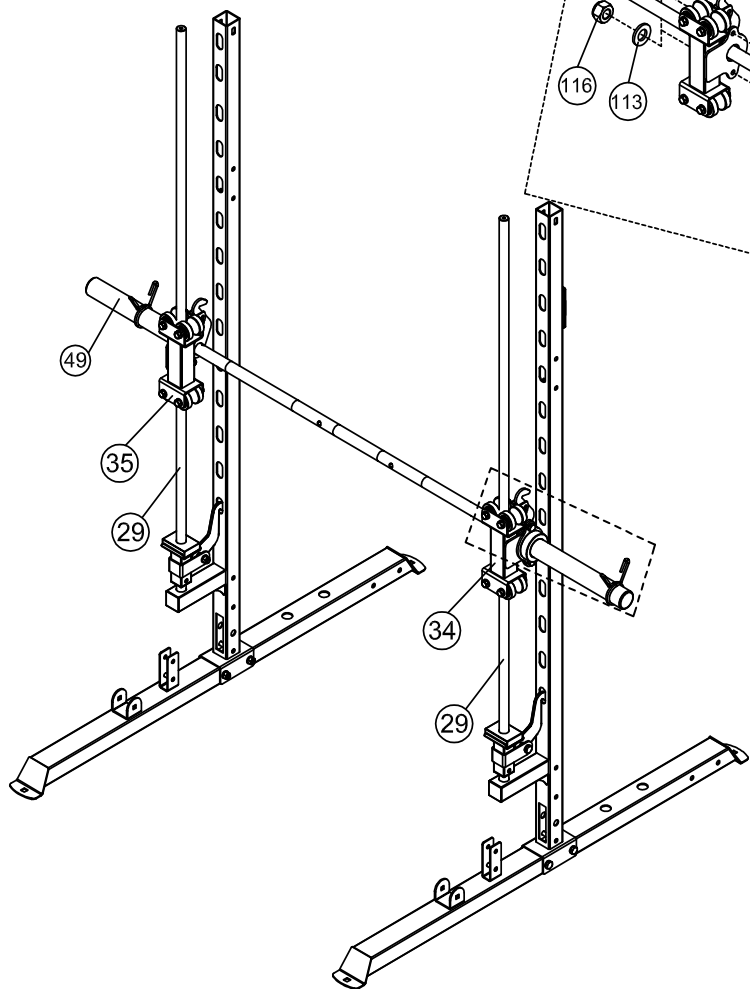
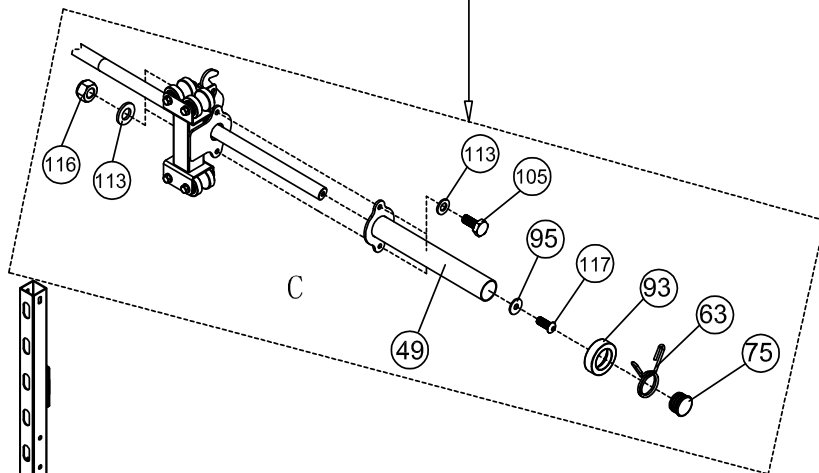
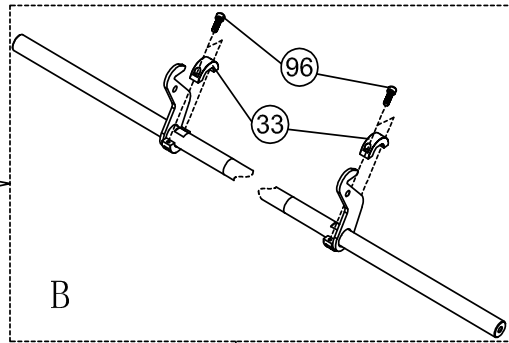
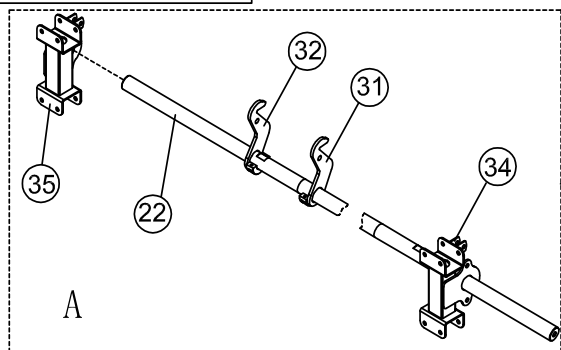
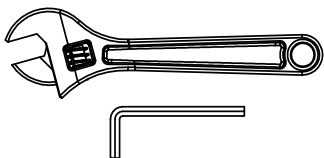

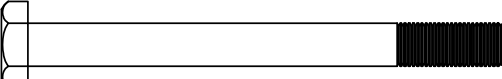
- |     |   |    |           |     |   |     |     |
|-----|---|----|-----------|-----|---|-----|-----|
| 99  |  | x4 | M10x 90mm | 113 |  | x12 | Φ10 |
| 101 |  | x4 | M10x 75mm | 116 |  | x8  | M10 |
| 115 |  | x4 | Φ30xΦ10.5 |     |   |     |     |

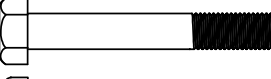

- |     |   |    |           |     |   |    |           |
|-----|---|----|-----------|-----|---|----|-----------|
| 105 |  | x4 | M10x 25mm | 117 |  | x2 | M10x 25mm |
| 96  |  | x4 | M8x 20mm  | 113 |  | x8 | Φ10       |
| 95  |  | x2 | Φ37xΦ13.5 | 116 |  | x4 | M10       |

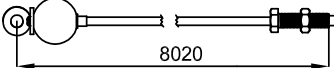

- |     |   |     |            |     |   |     |      |
|-----|---|-----|------------|-----|---|-----|------|
| 97  |    | x2  | M12x 135mm | 113 |  | x40 | Φ10  |
| 102 |    | x2  | M10x 70mm  | 114 |  | x4  | Φ12  |
| 104 |    | x18 | M10x 45mm  | 116 |  | x20 | M10  |
| 64  |   | x2  | M12        | 18  |  | x2  | 8020 |

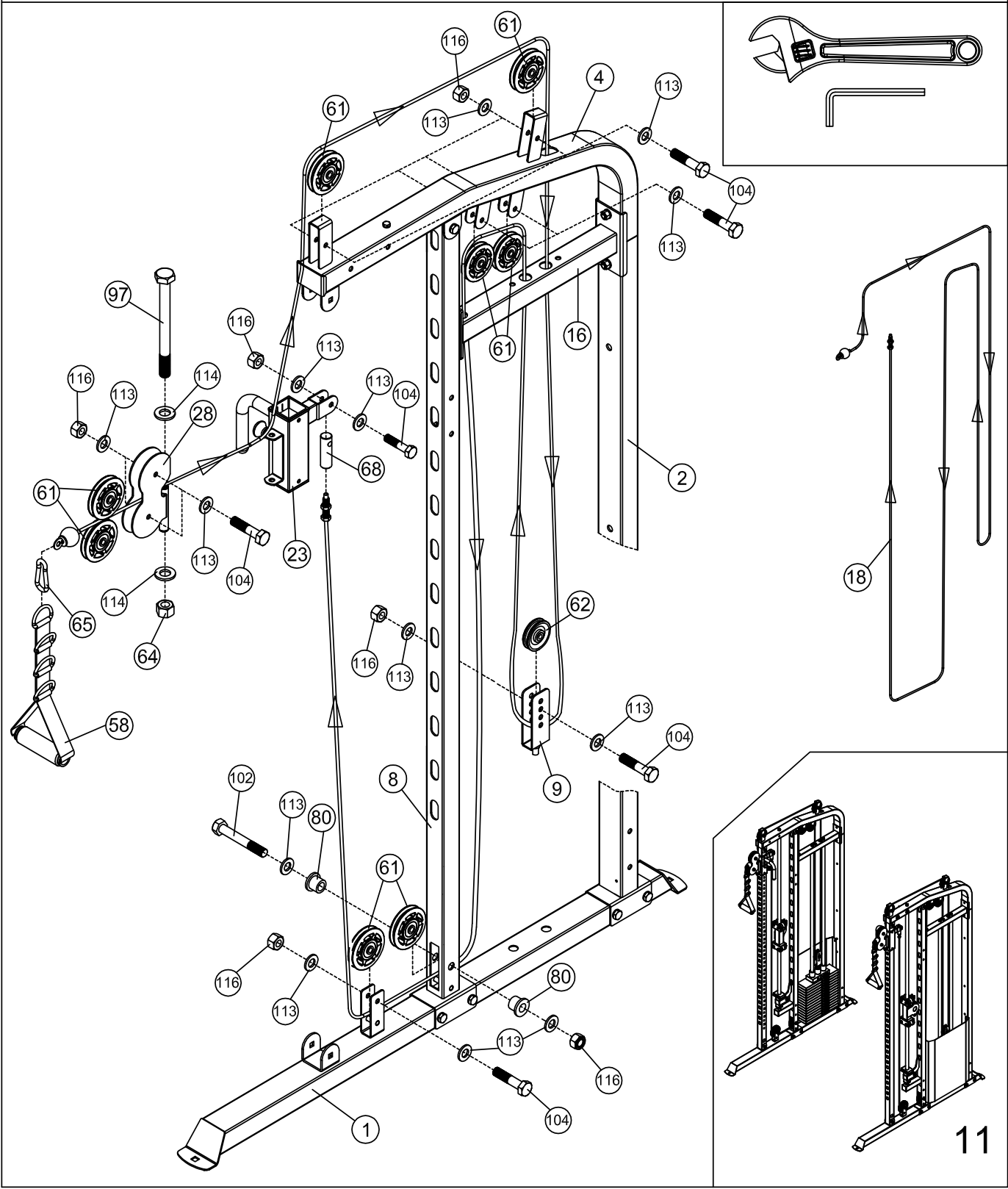

- |     |  |    |            |     |  |    |     |
|-----|--|----|------------|-----|--|----|-----|
| 99  |  | x2 | M10 x 90mm | 113 |  | x4 | Φ10 |
| 98  |  | x1 | M12 x 90mm | 114 |  | x2 | Φ12 |
| 109 |  | x2 | M8 x 35mm  | 116 |  | x2 | M10 |
| 64  |  | x1 | M12        |     |  |    |     |

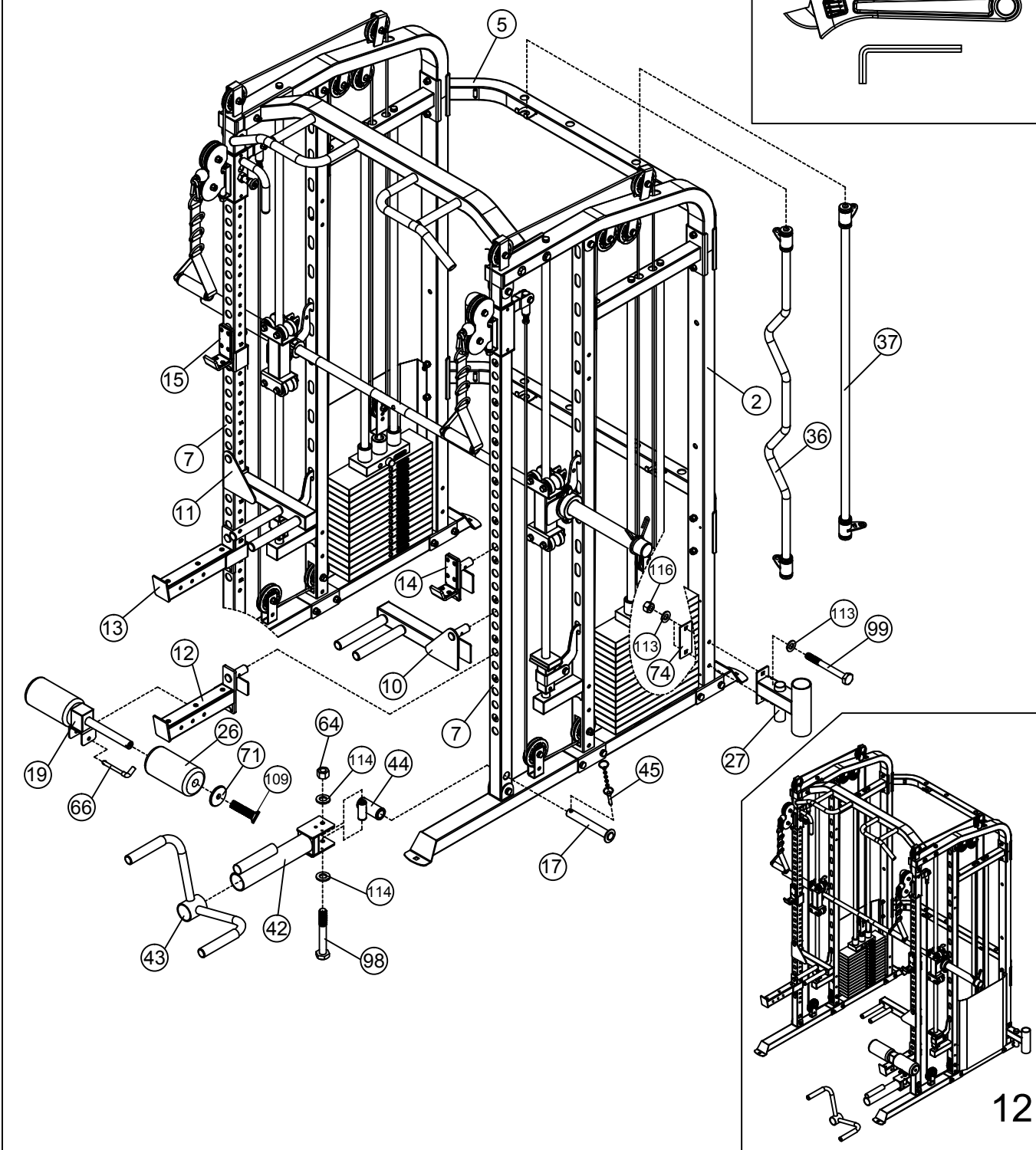
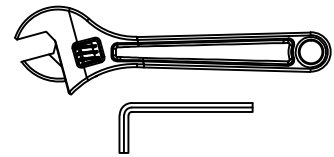

105

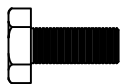

x6 M10x 25mm

113



x6 Φ10

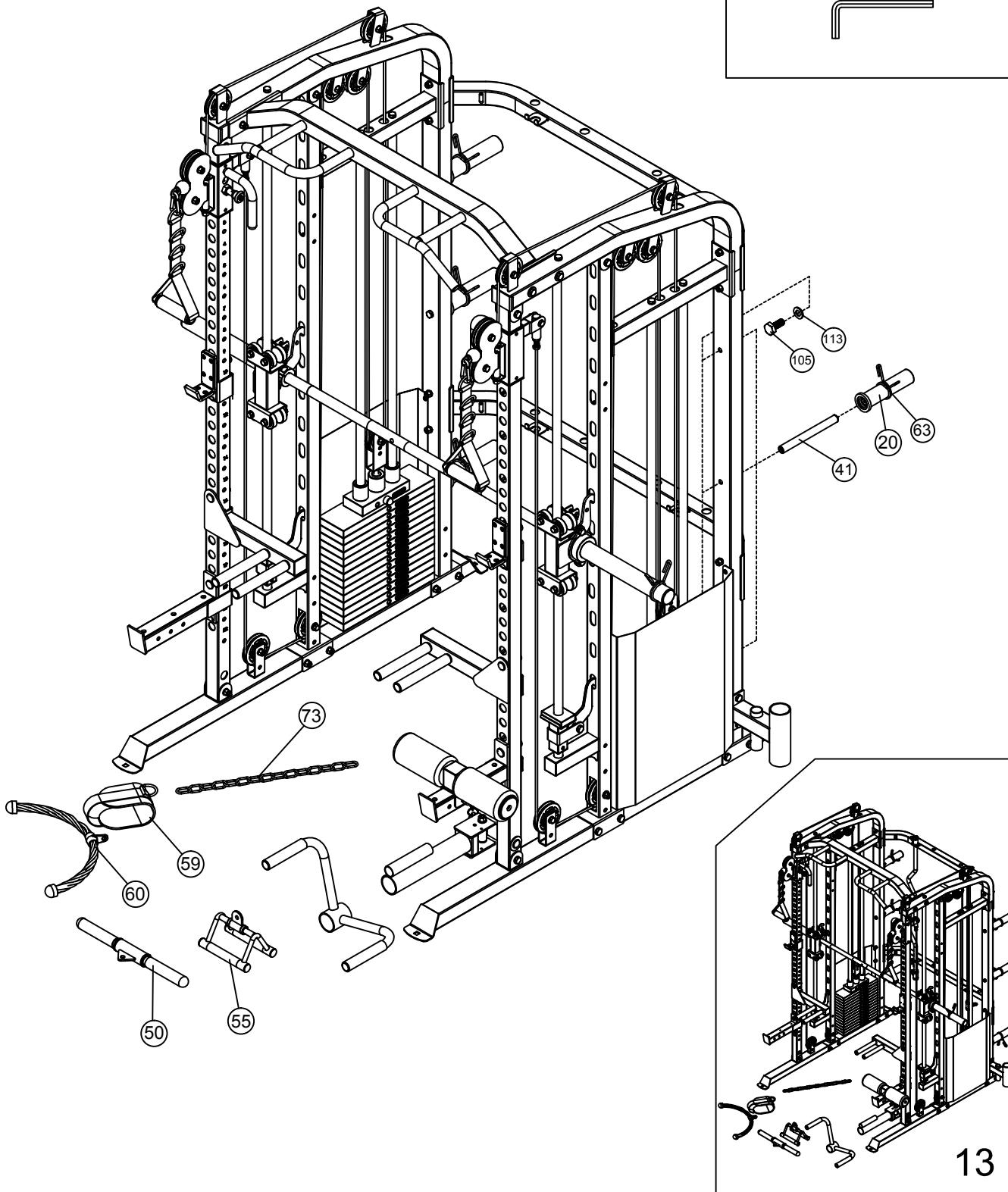
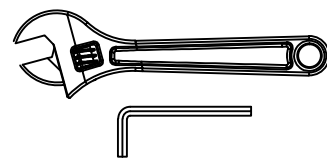

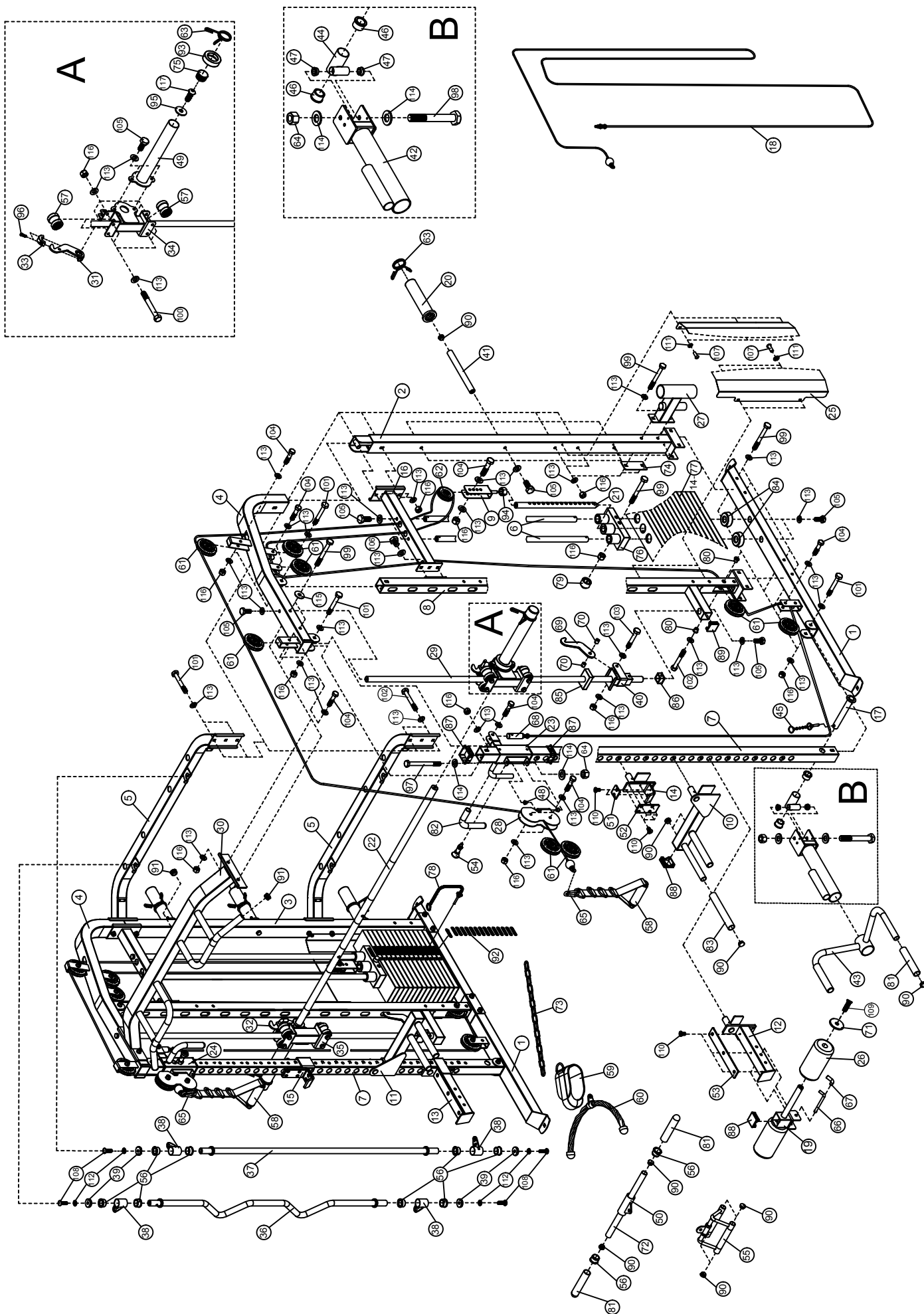

## PARTS LIST

PART NO.	DESCRIPTION	SIZE	QUANTITY
1	Base Framem		2
2	Rear Post L		1
3	Rear Post R		1
4	Top Frame		2
5	Connecting Frame Rear		2
6	Guide Rod Rear	φ25×1712	4
7	Front Guide Shaft	□50×3×1950	2
8	Intermediate Stand		2
9	Porous pulley group		2
10	Dip Bar L		1
11	Dip Bar R		1
12	Long Safety Rack L		1
13	Long Safety Rack R		1
14	Short Safety Rack L		1
15	Short Safety Rack R		1
16	Connecting Frame		2
17	Rotating Shaft	φ25×183	1
18	Double Pull Cable	L=8020mm	2
19	FOAM Frame		1
20	Short barbell casing		6
21	Choose shaft		2
22	Weight Rod	φ30×1865	1
23	Frame Slider L		1
24	Frame Slider R		1
25	Shield		2
26	FOAM	φ95×φ22×180	2
27	Barbell Socket		1
28	Pulley Case		2
29	Guide Rod	φ25×1770	2
30	Horizontal Bar		2
31	Hanging Bar L		1
32	Hanging Bar R		1
33	Semicircle Fixed Seat		2
34	Roller Rack L		1
35	Roller Rack R		1
36	Cambered Bar (attachment)		1
37	Straight Bar (attachment)		1
38	Hub		4
39	Bar End	φ38×φ9×8	4
40	Safety Hook Bracket		2
41	Weight Stow Rod	φ25×245	6
42	Rotating Frame		1
43	Handle		1
44	Spacer		1
45	Pop Pin		1
46	Bushing	φ38×φ34×φ25×22	2
47	Bushing	φ25×φ21.8×φ12.2×8	2
48	Bushing	φ19×φ16×φ12×8	4
49	Long Sleeve Barbell Rack	φ50×350	2
50	Small Grip Frame		1

## PARTS LIST

PART NO.	DESCRIPTION	SIZE	QUANTITY
51	Rack Liner	52×45×5	2
52	Rack Liner	110×52×5	2
53	Rack Liner	280×45×5	2
54	Moving Lock Pin		2
55	V-type Handle		1
56	Bushing	φ38×φ34×φ27×26	10
57	Roller set		8
58	Nylon Strap Iso-Handle	HERS	2
59	Ankle Strap	PH1300	1
60	Rope		1
61	Pulley with Bearings	φ96	16
62	Small Pulley with Bearings	φ75×25	2
63	Spring Clip	φ49	8
64	Nut	M12	3
65	Hook	φ8	2
66	L Spring Pins	φ10×115	1
67	Rubber Sleeve	φ13×φ9.5×58	1
68	Adjustable Axle	φ25×75	2
69	Safe Hook	R25×φ11×6	2
70	Spacer	φ16×φ11×16	4
71	Plate	φ68×5	2
72	Small Handle Tube	φ25×1.5×370	1
73	15-Joint Chain		1
74	Bracket		1
75	Rectangular End Cap		2
76	Selector Stem		2
77	Weight Plate		28
78	Weight Select Pin		2
79	Bolt cap		2
80	Pulley casing		4
81	Short Dips Handle	φ23×150	4
82	Dips Handle	φ24×φ18×227	2
83	Dips Handle	φ23×200	4
84	Rubber Stopper	φ62×φ24.5×25	4
85	Rubber Stopper	80×56×20	2
86	Safety Hook Bracket Guides	38×26×30×3	2
87	Slide Guide	□60×2.5×□50×25	4
88	Rectangular End Cap	□50	3
89	Rectangular End Cap	□45	2
90	Rectangular End Cap	φ25	22
91	Rectangular End Cap	φ28	6
92	Choose iron stickers	51×13	2
93	Weight plate cushion	φ78×φ47.5×23	2
94	Hex Nut	M12	2
95	Washer	φ37×φ13.5×3	2
96	Socket Cap Screws	M8×20	4
97	Hex Bolts	M12×135	2
98	Hex Bolts	M12×90	1
99	Hex Bolts	M10×90	16
100	Hex Bolts	M10×85	8



## PARTS LIST

PART NO.	DESCRIPTION	SIZE	QUANTITY
101	Hex Bolts	M10×75	10
102	Hex Bolts	M10×70	6
103	Hex Bolts	M10×65	2
104	Hex Bolts	M10×45	18
105	Hex Bolts	M10×25	22
106	Hex Bolts	M10×15	4
107	Self-tapping screws	M6×16	10
108	Allen Bolt	M8×25	4
109	Allen Bolt	M8×35	2
110	Hex-lob Screw	M6×12	18
111	Washer	6	10
112	Washer	8	4
113	Washer	10	142
114	Washer	12	6
115	Washer	φ30×φ10.5×2.5	4
116	Nut	M10	64
117	Allen Bolt	M10×25	2
	Allen wrench	6#	1
	Allen wrench	5#	1
	Allen wrench	4#	1



## NEŽ ZAČNETE

Děkujeme, že jste si vybrali právě CBT. S ohledem na vlastní bezpečí a přínosy využívání produktu, se před jeho použitím řádně seznámte s návodem. Jako výrobce se snažíme našim klientům zaručit plnou spokojenost.

## DŮLEŽITÉ BEZPEČNOSTNÍ POKYNY

Výrobek je určen výlučně k domácímu použití a byl navržen tak, aby byla zajištěna optimální bezpečnost. Dodržujte následující pokyny:

1. V případě možnosti existence zdravotních překážek ve využívání tohoto zařízení se před započítím tréninku poraďte s lékařem. Rozhodnutí lékaře je nezbytné především v případě používání léků ovlivňujících práci srdce, krevní tlak a hladinu cholesterolu. Rozhodnutí je nezbytné i v případě osob starších 35 let, které mají zdravotní problémy.
2. Před započítím tréninku vždy proveďte rozcvičku.
3. V průběhu tréninku a po jeho ukončení zajistěte, aby k zařízení neměly přístup děti a zvířata.
4. Zařízení postavte na suchý, stabilní a řádně vyrovnaný povrch. Z bezprostřední blízkosti zařízení odstraňte všechny ostré předměty. Zařízení chraňte před vlhkostí, případné nerovnosti povrchu vyrovnejte. Doporučujeme použít speciální antisklizovou podložku, která zabrání posouvání se zařízení během tréninku.
5. Dávejte si pozor na znepokojující signály. Nevhodné nebo nadměrné cvičení je zdraví nebezpečné. Pokud se během tréninku objeví bolesti hlavy, závrať, bolest na hrudi, nepravidelný srdeční rytmus nebo jiné znepokojivé signály, okamžitě přerušete trénink a poraďte se s lékařem ohledně pokračování v tréninku. Úrazy mohou být způsobeny nepravidelným nebo příliš intenzivním tréninkem.
6. Volný prostor by neměl být menší než 0,6m a větší než dostupný tréninkový prostor. Volný prostor musí zahrnovat také prostor pro bezpečné nouzové opuštění zařízení. Tam, kde jsou zařízení umístěna vedle sebe, může být velikost volného prostoru rozdělena.
7. Před prvním použitím, a dále v pravidelných intervalech, je potřeba kontrolovat upevnění šroubů a ostatních spojů.
8. Před započítím tréninku zjistěte upevnění jednotlivých částí a šroubů, které je spojují. Trénink je možné započít pouze v případě, že je zařízení řádně sestaveno.
9. Zařízení by mělo být pravidelně kontrolováno z hlediska opotřebení a poškození, pouze tehdy budou splněny bezpečnostní podmínky. Zvláštní pozornost je potřeba věnovat potahu a pěnovkám, které podléhají opotřebení nejrychleji. Poškozené části je potřeba co nejrychleji opravit nebo vyměnit-do té doby není možno zařízení používat.
10. Do otvorů nevkládejte žádné předměty.
11. Vějte pozor na čouhající regulační části a jiné konstrukční části, které by při tréninku mohly překážet.
12. Zařízení využívejte pouze v souladu s jeho určením. Jestliže bude některá část poškozena nebo opotřebena nebo se během tréninku objeví znepokojující zvuky, okamžitě přerušete trénink. Nepoužívejte zařízení, dokud nebude závada odstraněna.
13. Cvičte v pohodlném oblečení a sportovní obuvi. Vyhněte se volnému oblečení, které by se mohlo o vyčnívající části zachytit, nebo by mohlo omezovat volnost pohybu.
14. Zařízení spadá do třídy H podle normy EN ISO 20957-1 a je určeno výlučně k domácímu použití. Nemůže být použito k terapeutickým, rehabilitačním nebo komerčním účelům.
15. Během vedení nebo přenášení tohoto zařízení je potřeba mít správné držení těla, aby nedošlo k poškození páteře.
16. Zařízení je určeno pouze pro osoby dospělé. Děti bez dozoru držte v bezpečné vzdálenosti od zařízení.
17. Při montáži zařízení je potřeba přesně dodržovat návod a používat pouze části, které patří k zařízení. Před započítím montáže je potřeba zkontrolovat, zda všechny části, které jsou v seznamu, byly dodány.

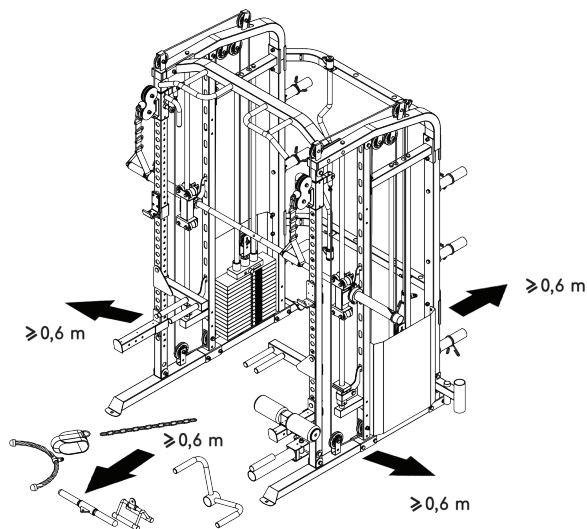

**UPOZORNĚNÍ: PŘED POUŽITÍM FITNESS ZAŘÍZENÍ JE POTŘEBA SI PŘEČÍST NÁVOD. NENESEME ZODPOVĚDNOST ZA ÚRAZY NEBO POŠKOZENÍ PŘEDMĚTŮ ZPŮSOBENÉ NESPRÁVNÝM POUŽÍVÁNÍM TOHOTO VÝROBKU.**

**ÚDRŽBA:** K čištění zařízení nepoužívejte agresivní čisticí prostředky. K odstraňování znečištění a prachu používejte měkký, vlhký hadřík. Zařízení přechovávejte na suchém místě tak, aby bylo chráněno před vlhkostí a korozi.

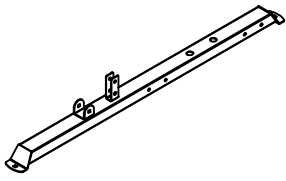

① × 2

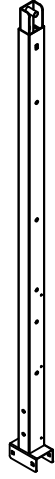

② × 1

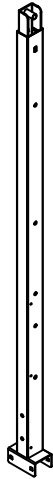

③ × 1

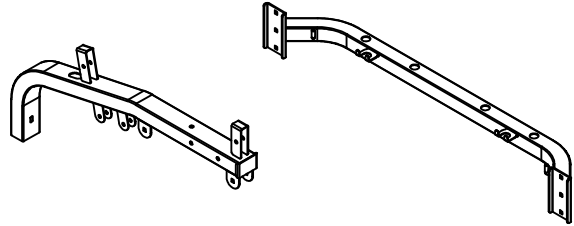

④ × 2

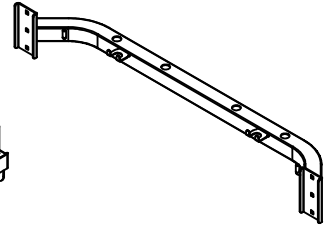

⑤ × 2



⑥ × 4



⑦ × 2

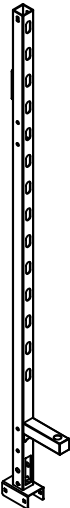

⑧ × 2



⑨ × 2

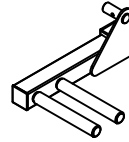

⑩ × 1

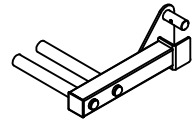

⑪ × 1

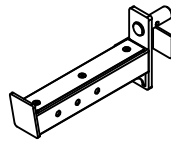

⑫ × 1

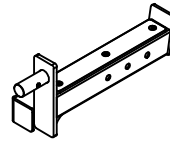

⑬ × 1



⑭ × 1



⑮ × 1

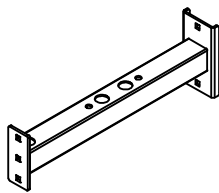

⑯ × 2

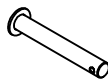

⑰ × 1

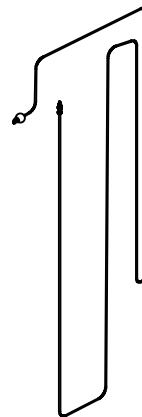

⑱ × 2

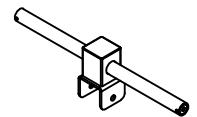

⑲ × 1

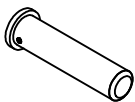

⑳ × 6

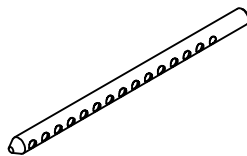

㉑ × 2

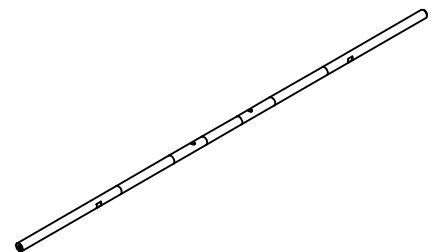

㉒ × 1

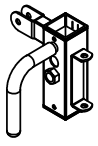

23 x 1

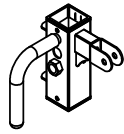

24 x 1

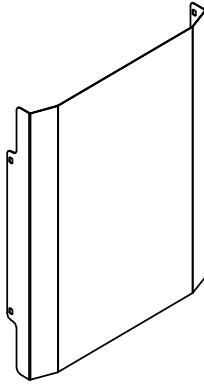

25 x 2

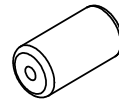

26 x 2

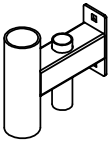

27 x 1



28 x 2

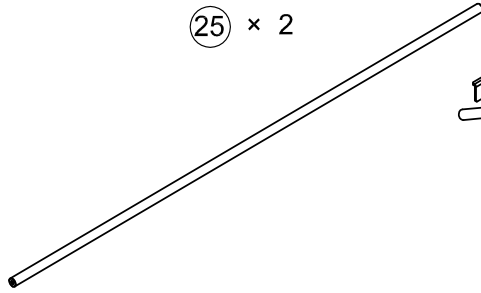

29 x 2

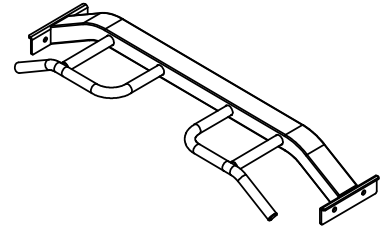

30 x 1



31 x 1



32 x 1



33 x 2

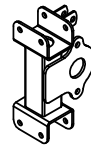

34 x 1



35 x 1

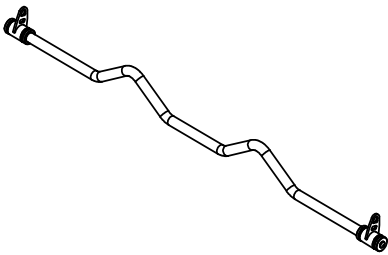

36 x 1

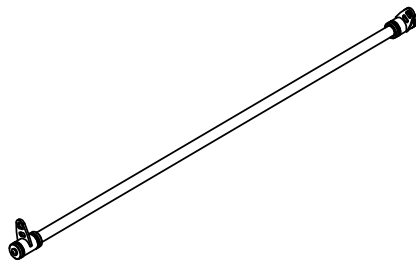

37 x 1

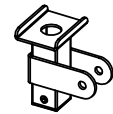

40 x 2

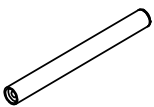

41 x 6

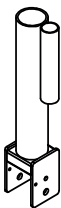

42 x 1

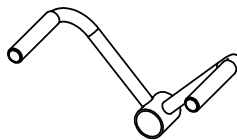

43 x 1

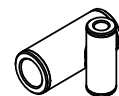

44 x 1

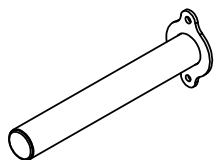

49 × 2

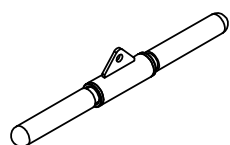

50 × 1



54 × 2

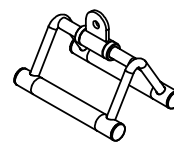

55 × 1



57 × 8

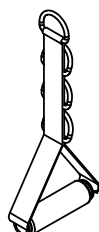

58 × 2



59 × 1

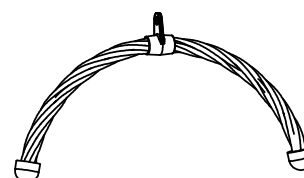

60 × 1



61 × 16



62 × 2

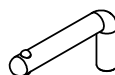

66 × 1



68 × 2



69 × 2



71 × 2



74 × 1



75 × 2

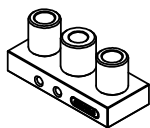

76 × 2

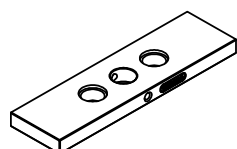

77 × 28



78 × 2



79 × 2



84 × 4



85 × 2



93 × 2



92 × 2

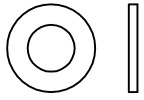

①111 × 10

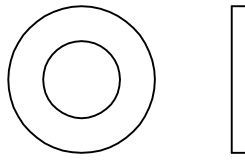

①113 × 142

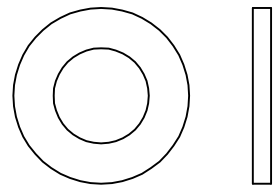

①114 × 6

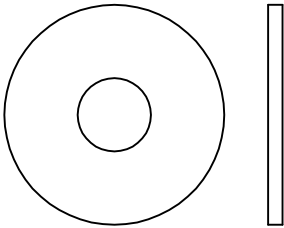

①115 × 4

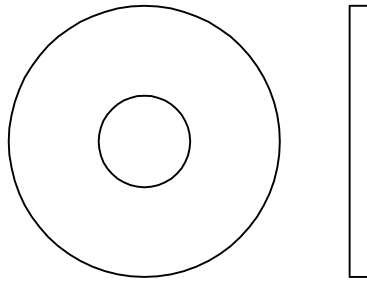

①95 × 2

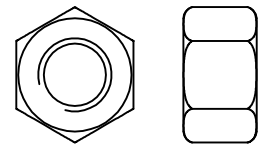

①116 × 64

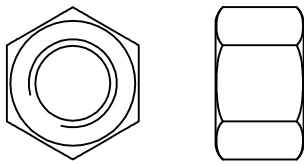

①64 × 3

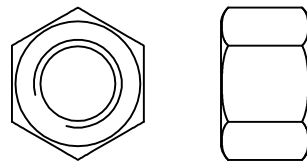

①94 × 2

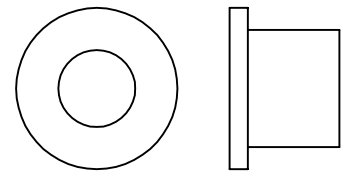

①80 × 4

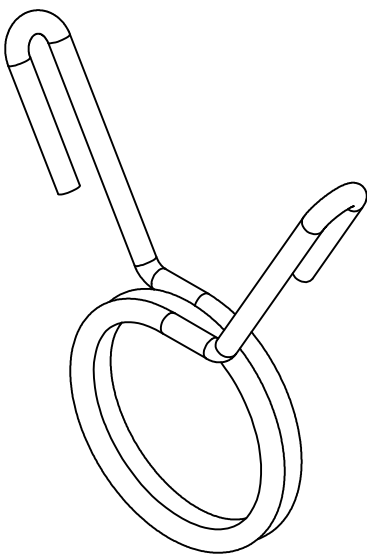

①63 × 8

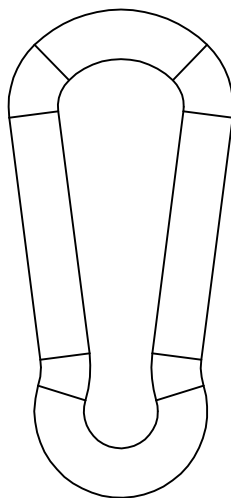

①65 × 2

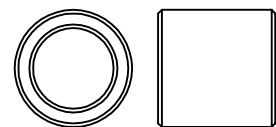

①70 × 4

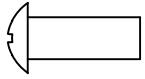

107 × 10



109 × 2

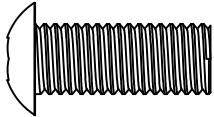

117 × 2

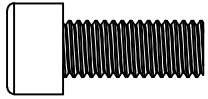

96 × 4

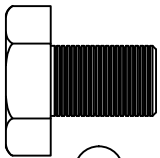

106 × 4



105 × 22

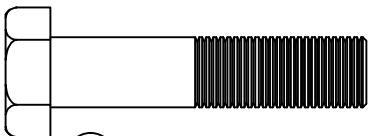

104 × 18

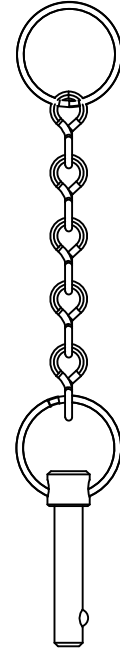

45 × 1

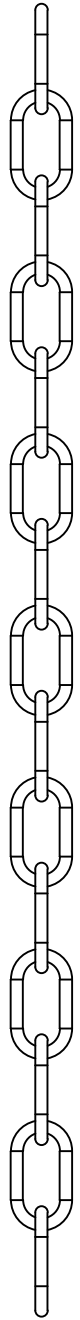

73 × 1

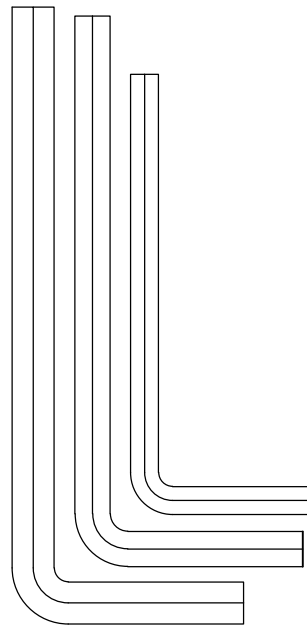

4# × 1

5# × 1



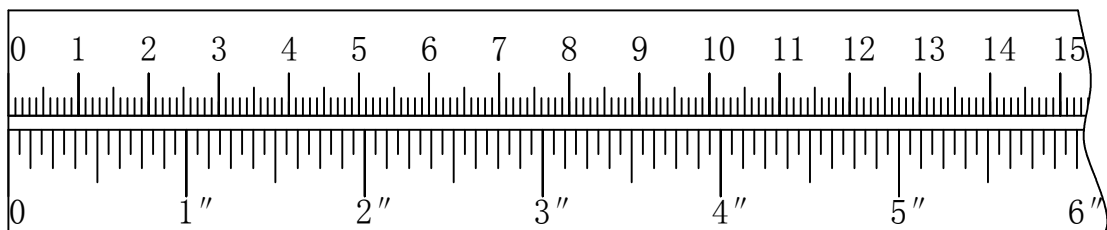

6# × 1

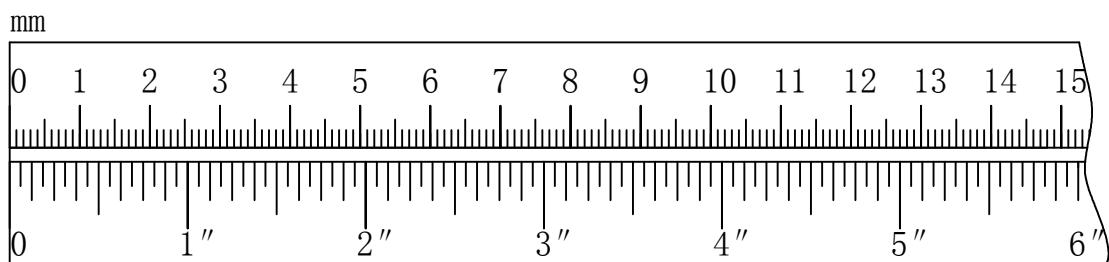
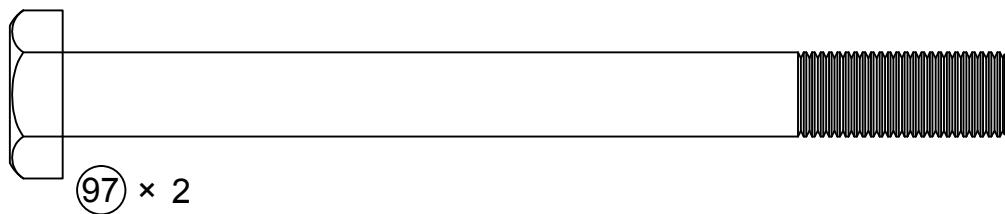
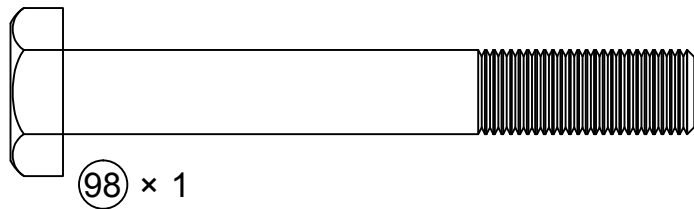
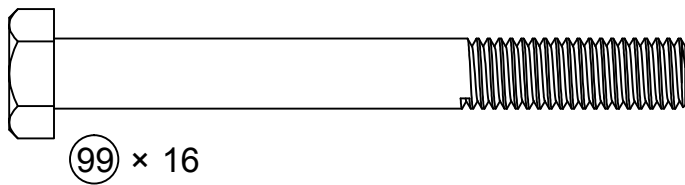
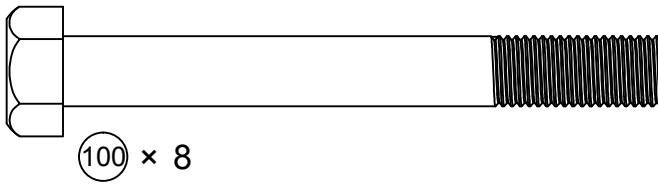
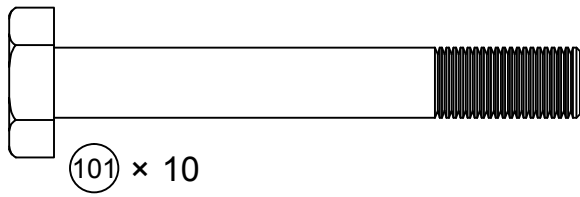
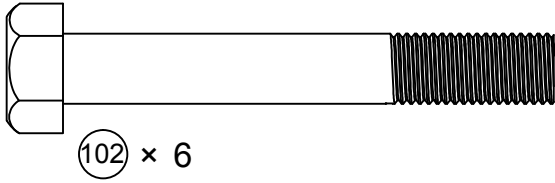
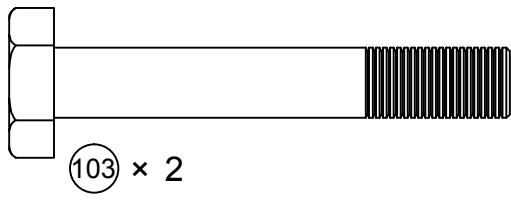
mm



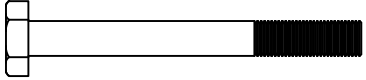





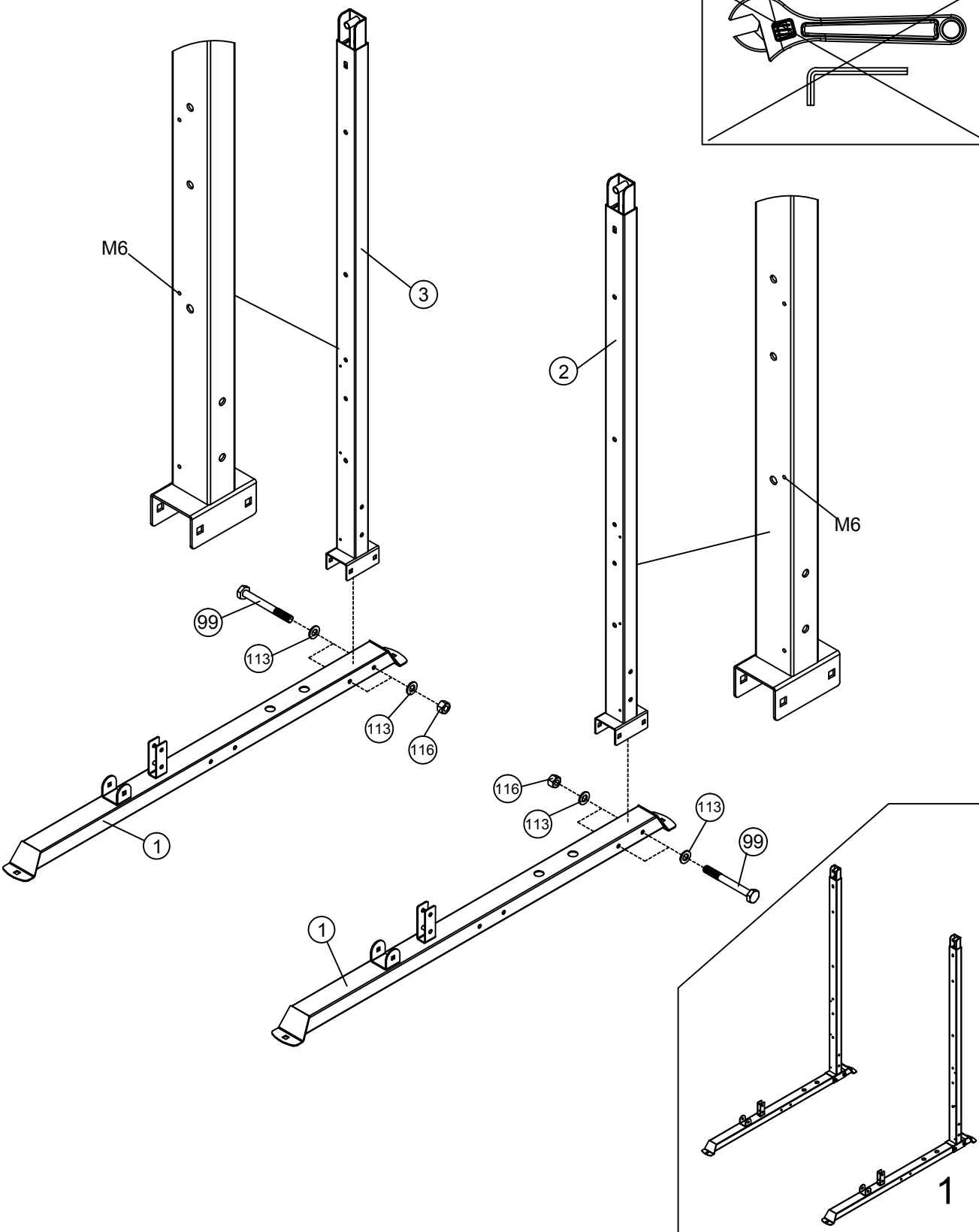
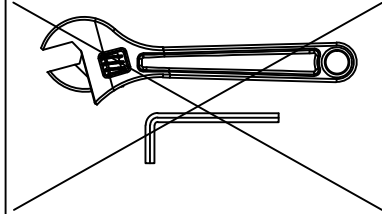

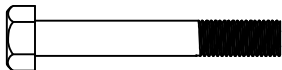



- 99  ×4 M10× 90mm
- 113   ×8 Φ10
- 116   ×4 M10

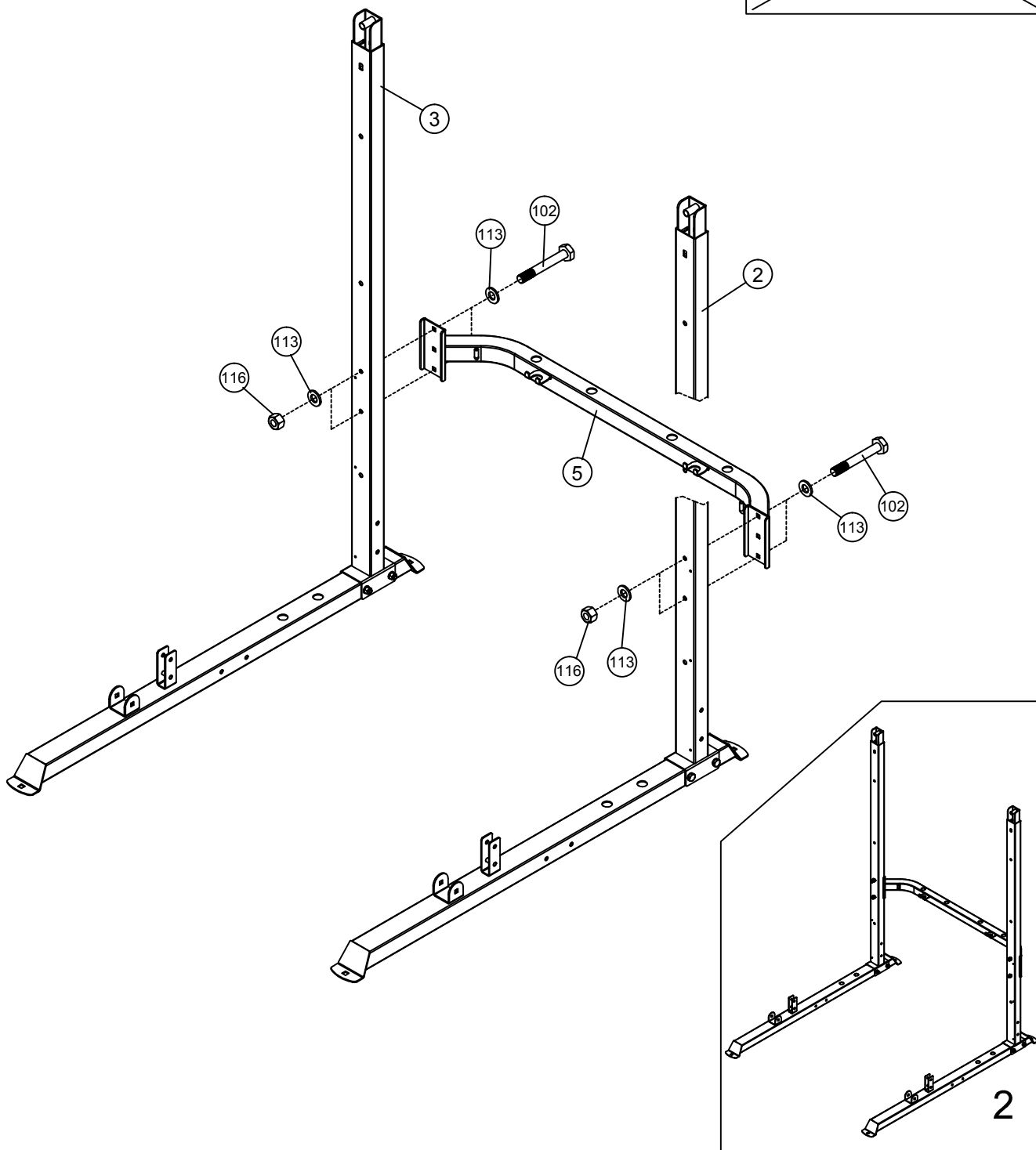
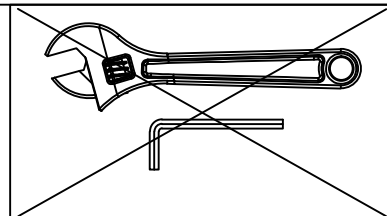

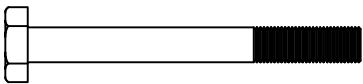
- |     |   |   |           |     |   |   |    |     |
|-----|---|---|-----------|-----|---|---|----|-----|
| 102 |  | x4  | M10x 70mm | 113 |  |  | x8 | Φ10 |
| 116 |  |  | x4        | M10 |   |   |    |     |

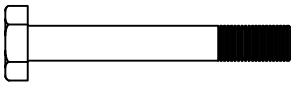

- |     |   |    |           |     |   |   |     |     |
|-----|---|----|-----------|-----|---|---|-----|-----|
| 99  |  | x4 | M10x 90mm | 113 |  |  | x12 | Φ10 |
| 101 |  | x2 | M10x 75mm | 116 |  |  | x6  | M10 |

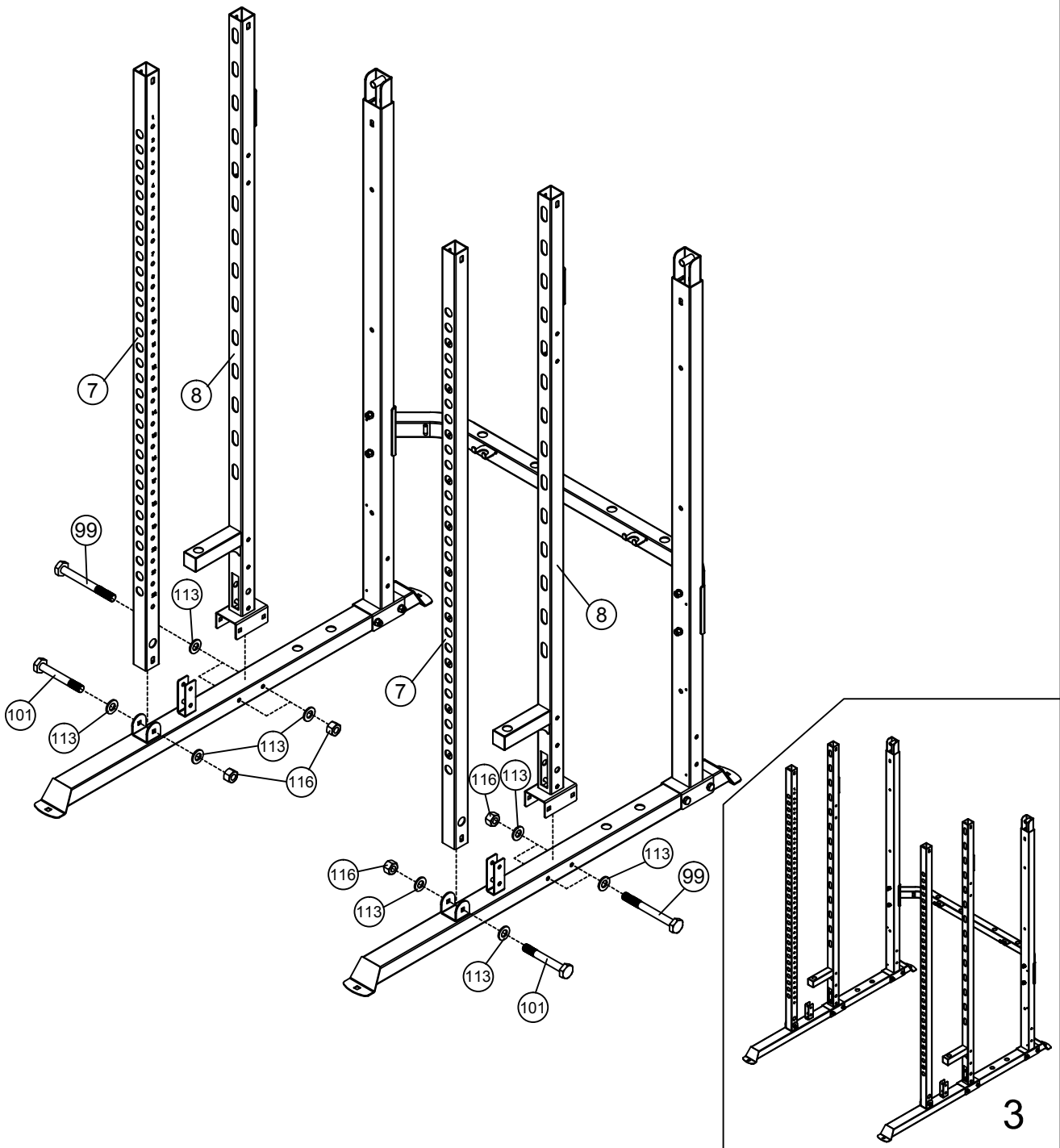
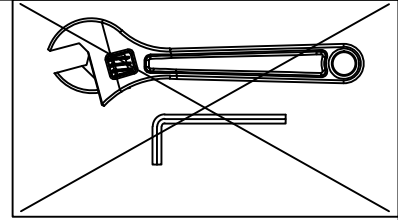

107  ×10 M6× 16mm

111   ×10 Φ6

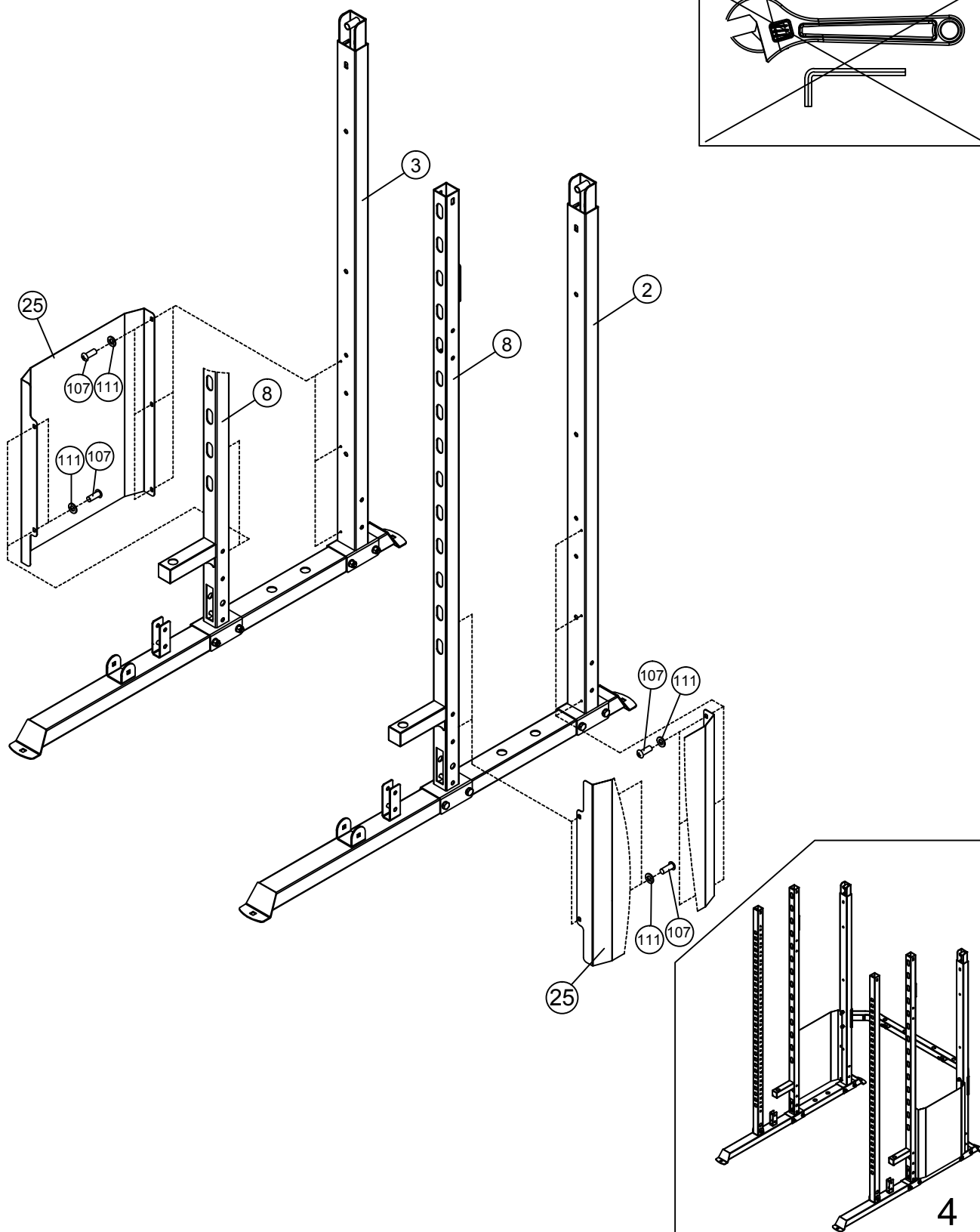

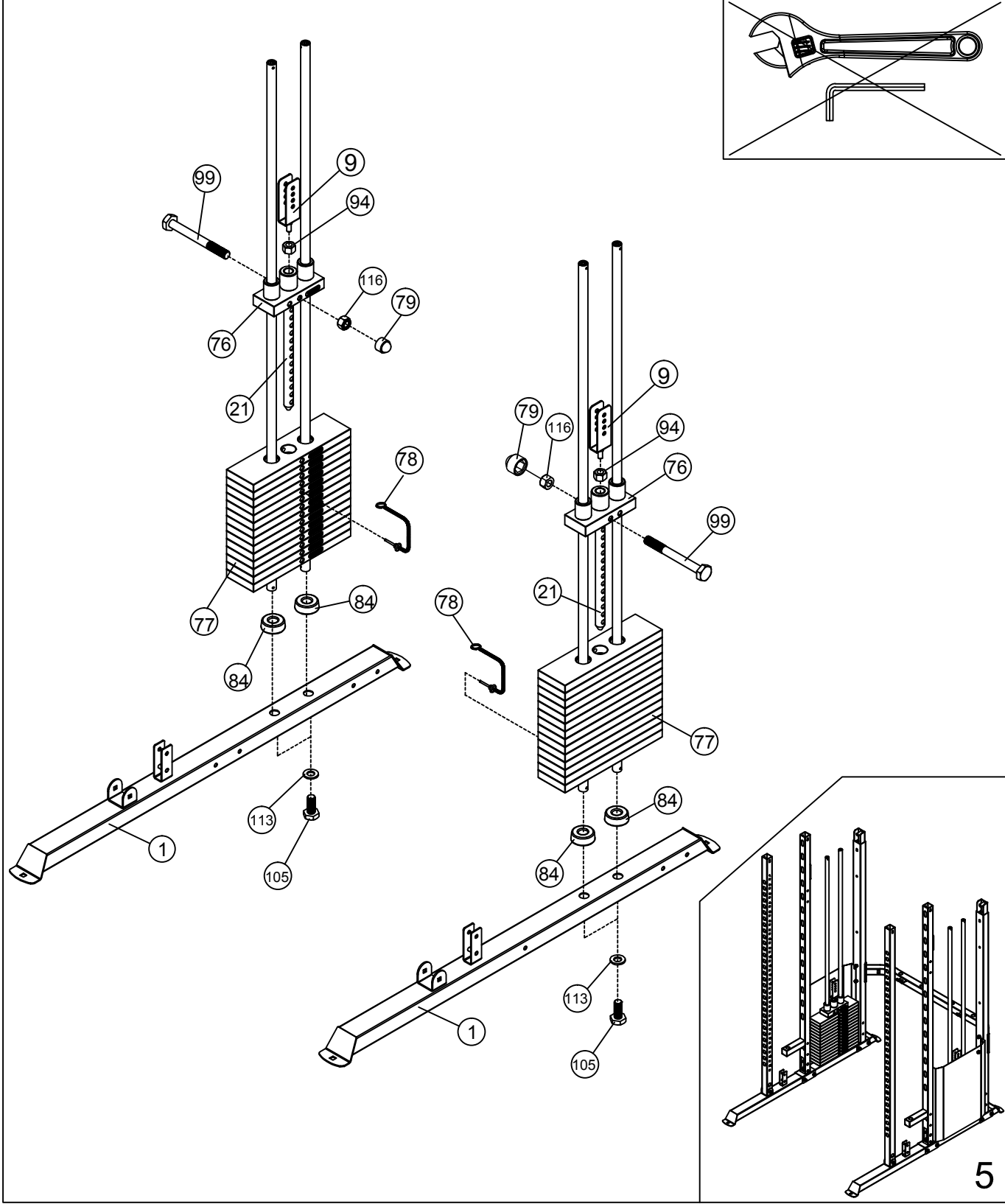
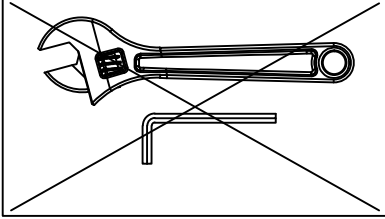

- |     |  |    |           |     |  |    |     |
|-----|--|----|-----------|-----|--|----|-----|
| 99  |  | x2 | M10x 90mm | 113 |  | x4 | Φ10 |
| 105 |  | x4 | M10x 25mm | 116 |  | x2 | M10 |
| 94  |  | x2 | M12       |     |  |    |     |

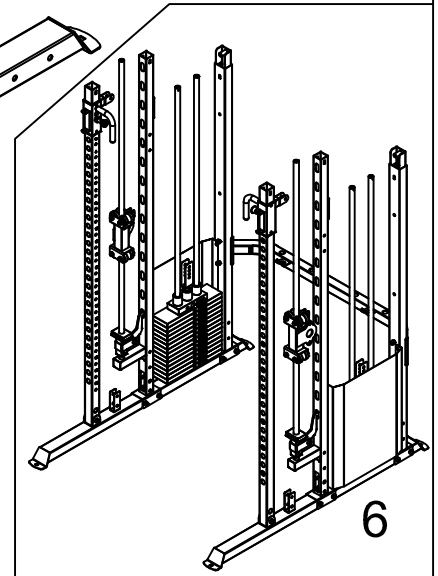
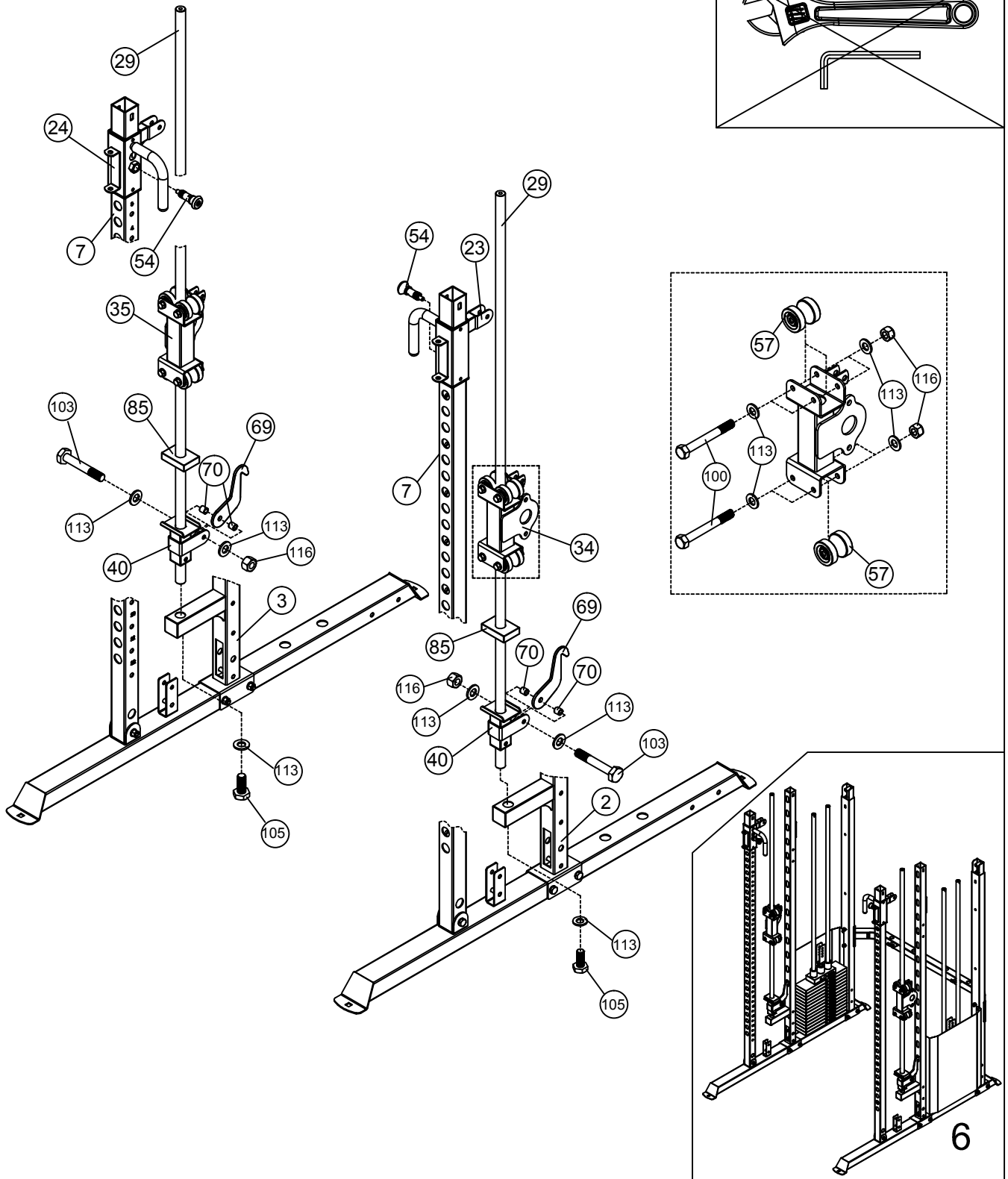
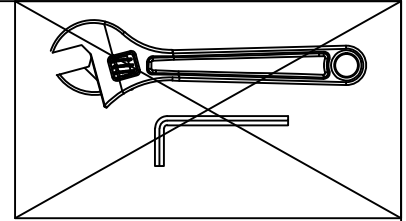

- |     |   |    |            |     |   |     |     |
|-----|---|----|------------|-----|---|-----|-----|
| 100 |  | ×8 | M10× 100mm | 113 |  | ×22 | Φ10 |
| 103 |  | ×2 | M10× 65mm  | 116 |  | ×10 | M10 |
| 105 |  | ×2 | M10× 25mm  |     |   |     |     |





105  ×4 M10× 25mm

113   ×8 Φ10

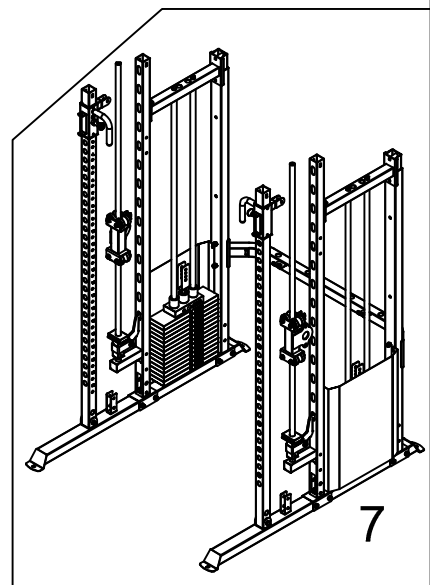
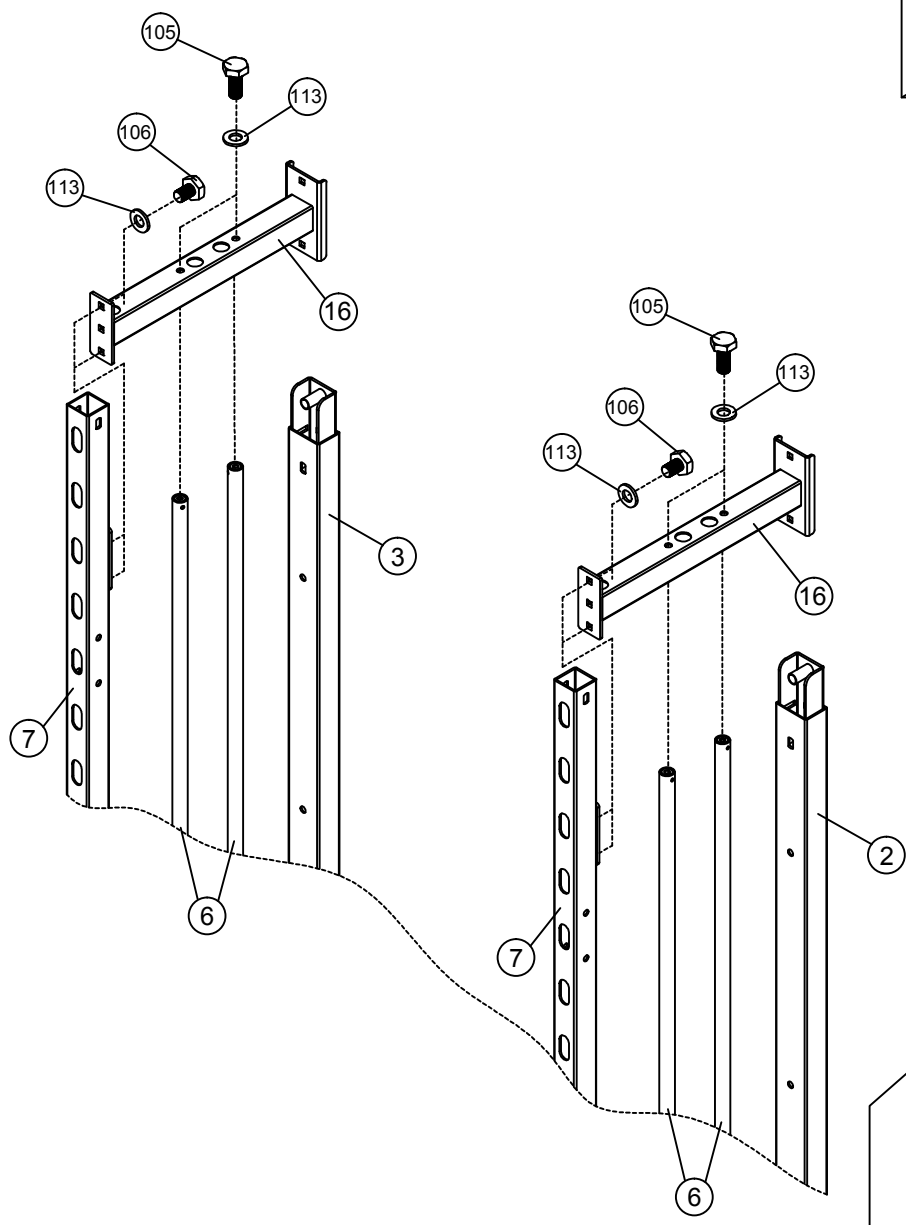
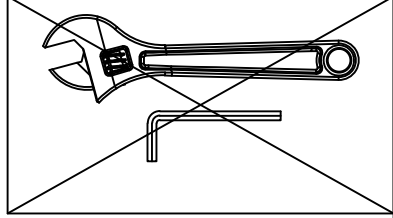

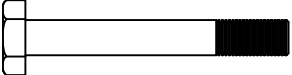
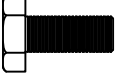

106  ×4 M10× 15mm

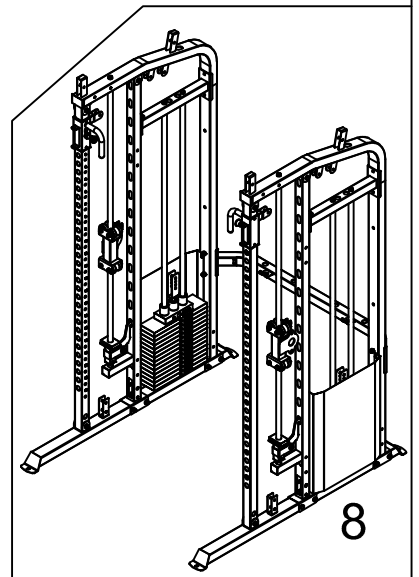
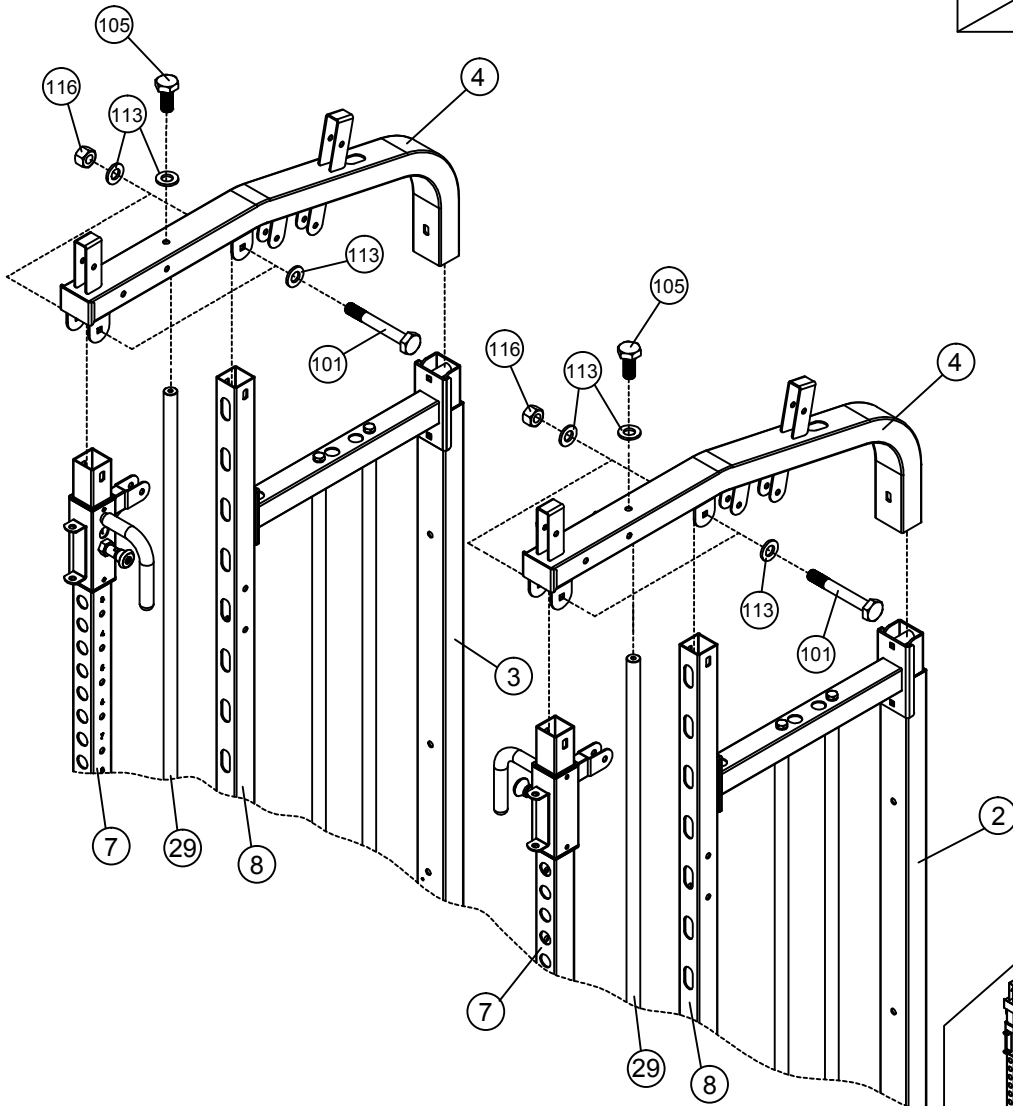
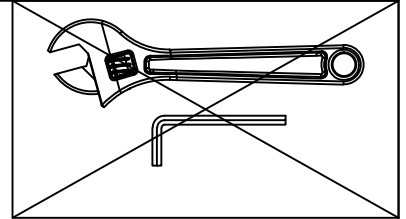



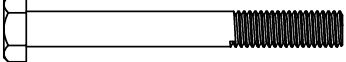

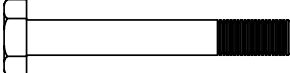
- |   |  |
|---|--|
| <p>(101)  ×4 M10× 75mm</p> <p>(105)  ×2 M10× 25mm</p> | <p>(113)  ×10 Φ10</p> <p>(116)  ×4 M10</p> |
|---|--|

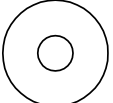

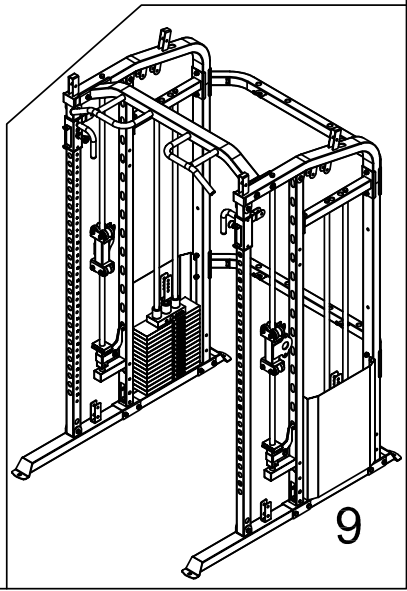
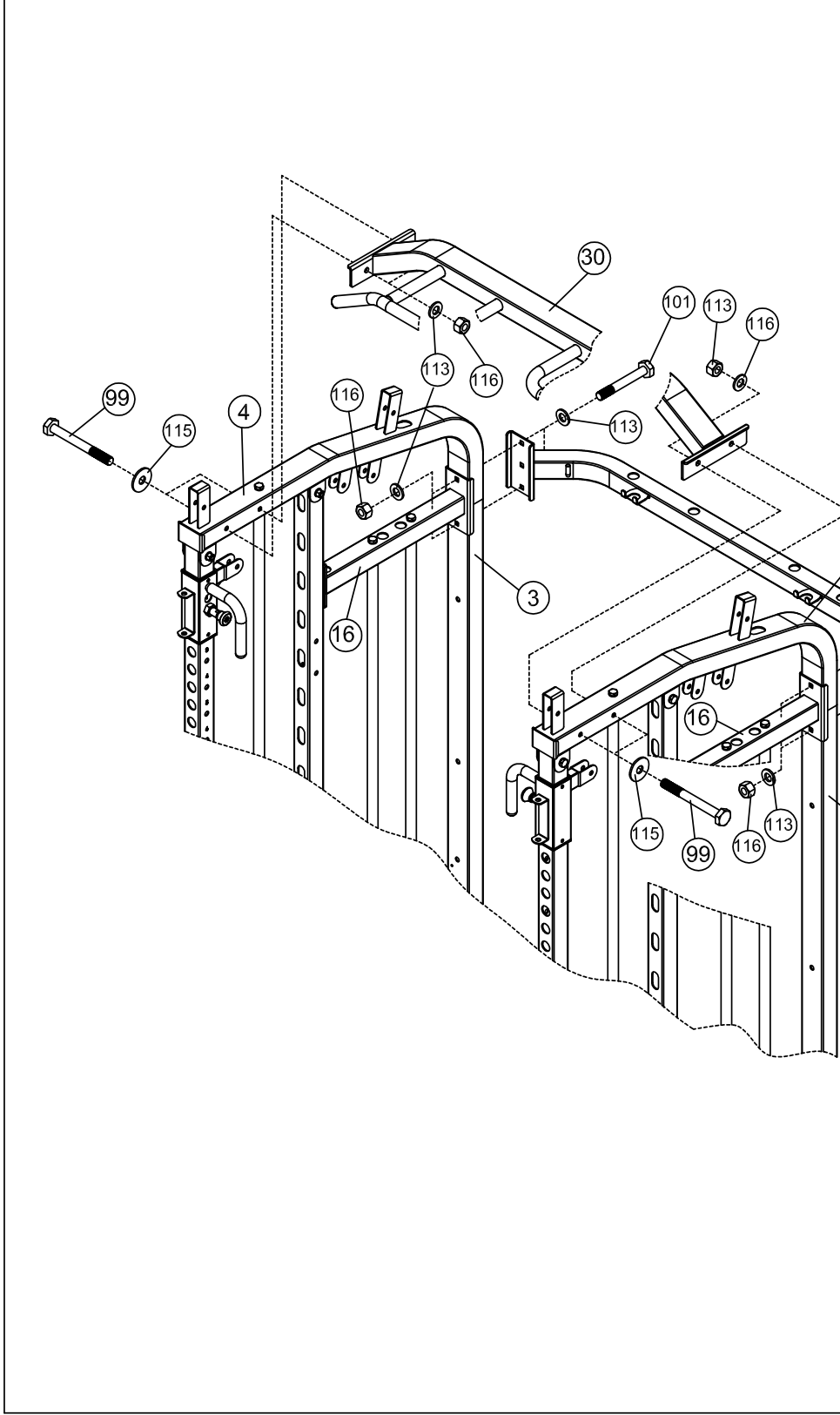
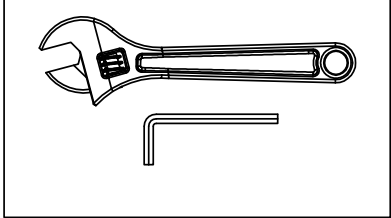

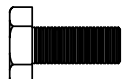
99		x4	M10x 90mm	113		x12	Φ10
101		x4	M10x 75mm	116		x8	M10
115		x4	Φ30xΦ10.5				

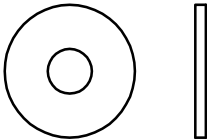
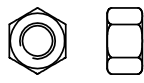

- |     |   |    |           |     |   |    |           |
|-----|---|----|-----------|-----|---|----|-----------|
| 105 |  | x4 | M10x 25mm | 117 |  | x2 | M10x 25mm |
| 96  |  | x4 | M8x 20mm  | 113 |  | x8 | Φ10       |
| 95  |  | x2 | Φ37xΦ13.5 | 116 |  | x4 | M10       |

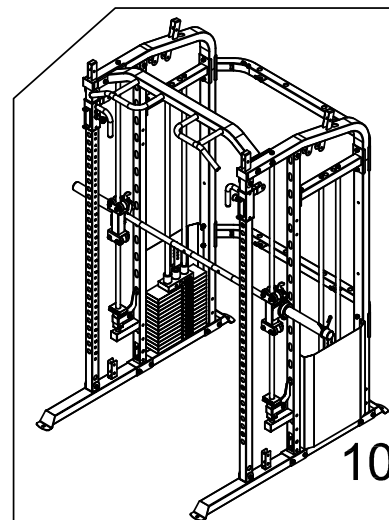
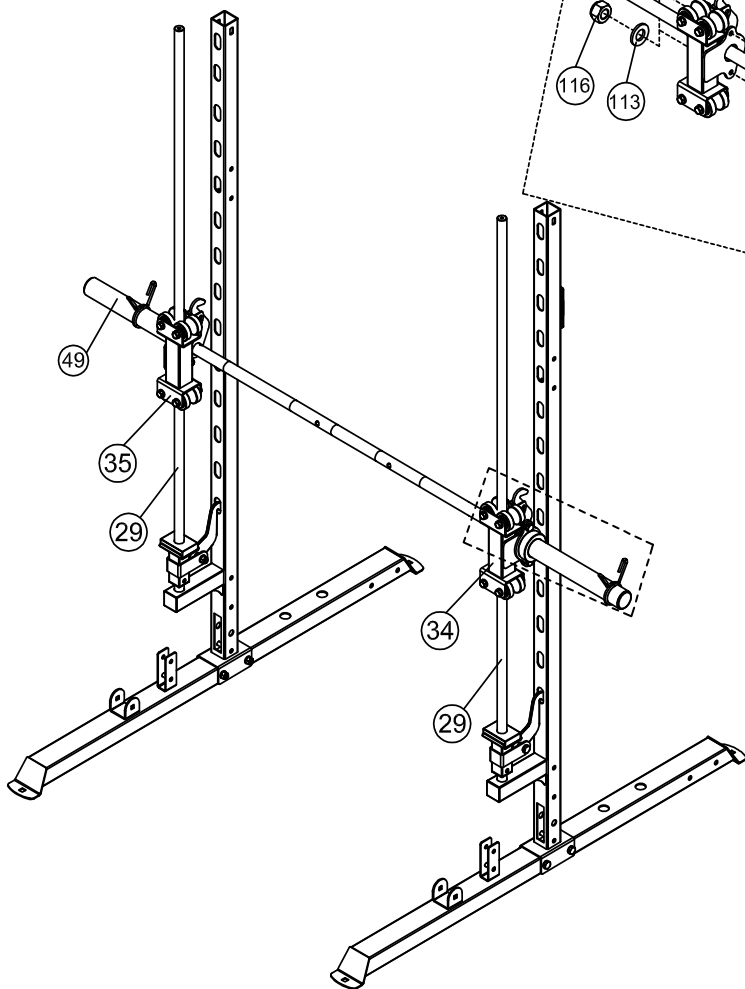
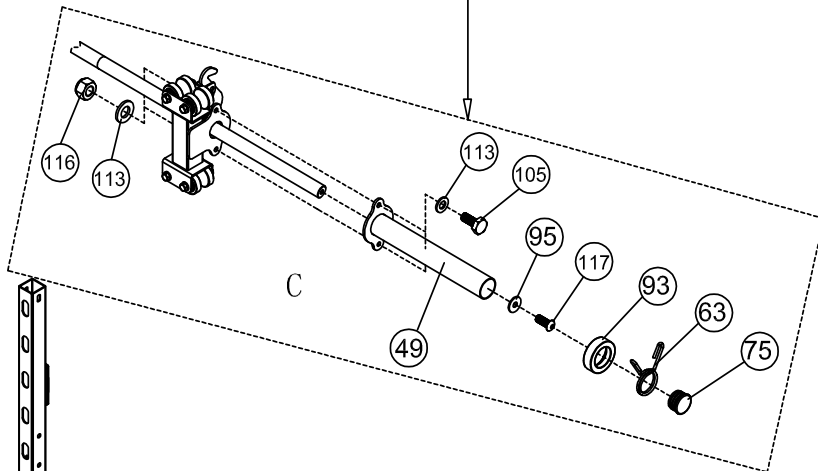
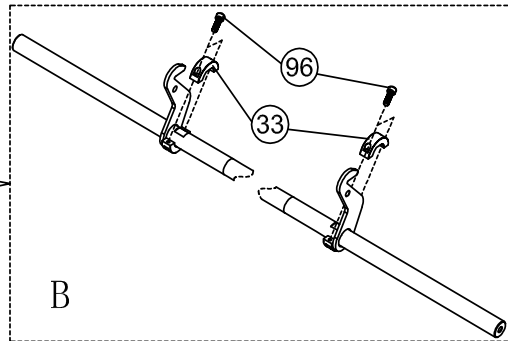
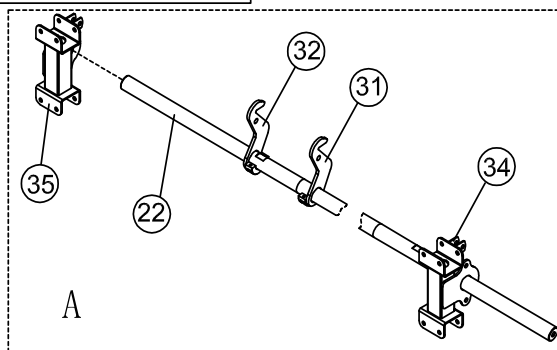
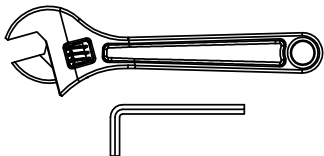

- |     |  |     |            |     |  |     |      |
|-----|--|-----|------------|-----|--|-----|------|
| 97  |  | x2  | M12x 135mm | 113 |  | x40 | Φ10  |
| 102 |  | x2  | M10x 70mm  | 114 |  | x4  | Φ12  |
| 104 |  | x18 | M10x 45mm  | 116 |  | x20 | M10  |
| 64  |  | x2  | M12        | 18  |  | x2  | 8020 |

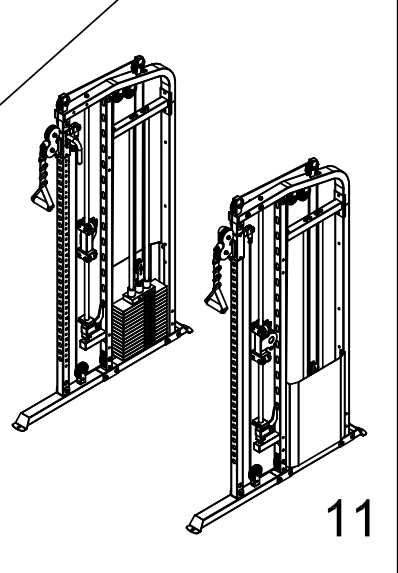
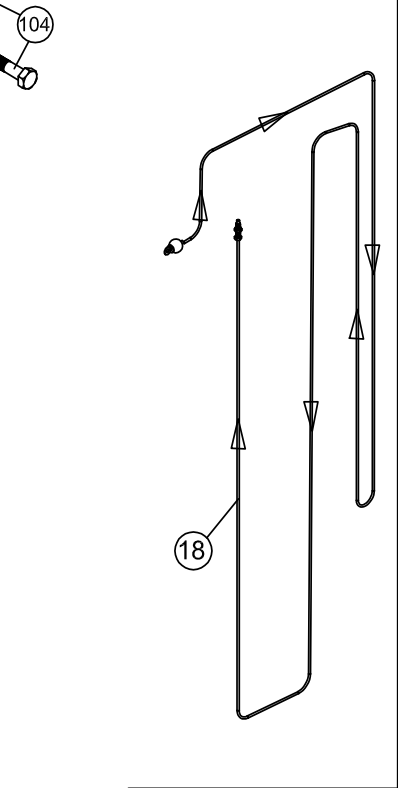
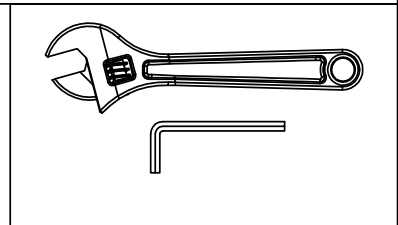
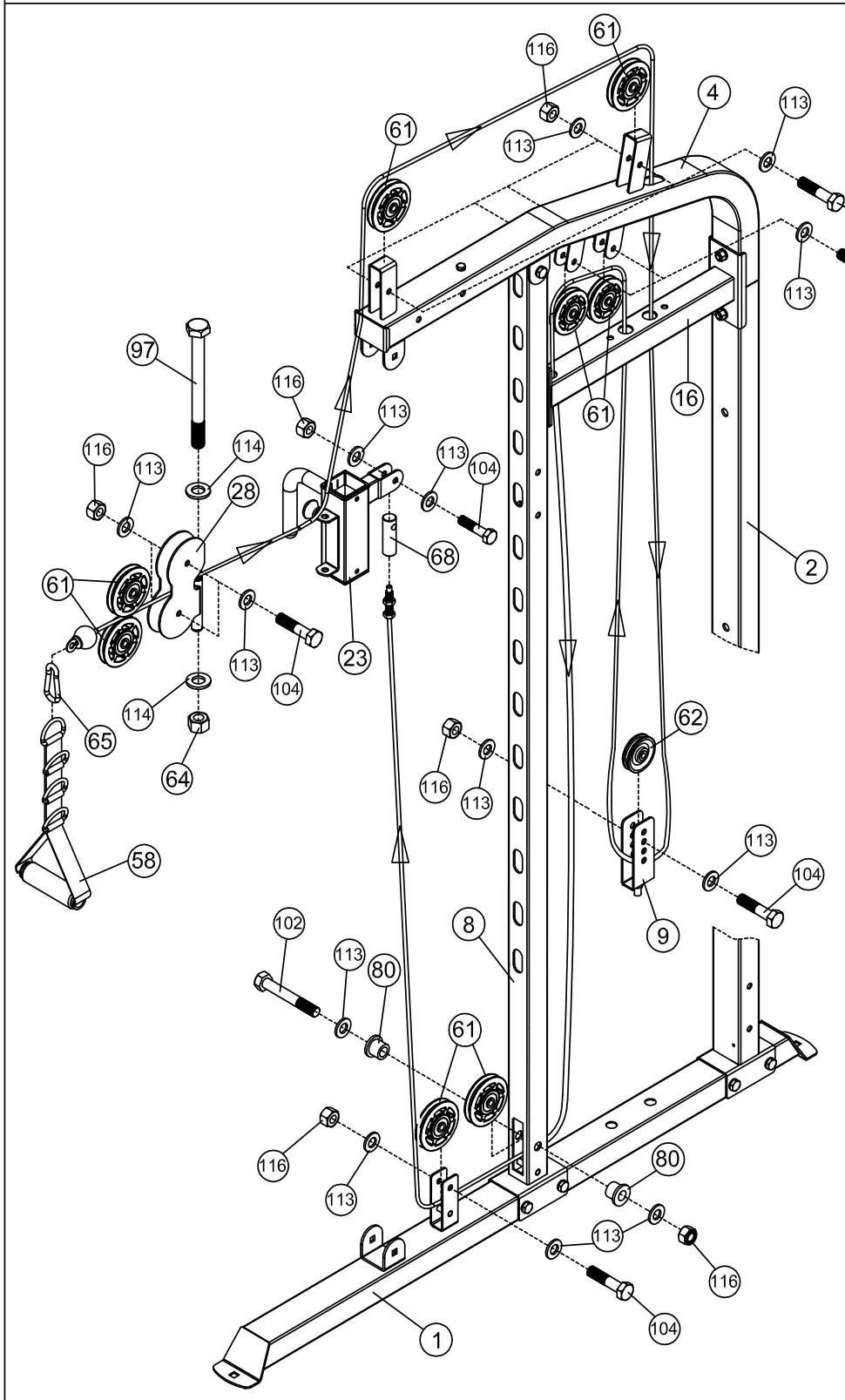

- |     |   |    |           |     |   |    |     |
|-----|---|----|-----------|-----|---|----|-----|
| 99  |  | ×2 | M10× 90mm | 113 |  | ×4 | Φ10 |
| 98  |  | ×1 | M12× 90mm | 114 |  | ×2 | Φ12 |
| 109 |  | ×2 | M8 × 35mm | 116 |  | ×2 | M10 |
| 64  |  | ×1 | M12       |     |  |    |     |

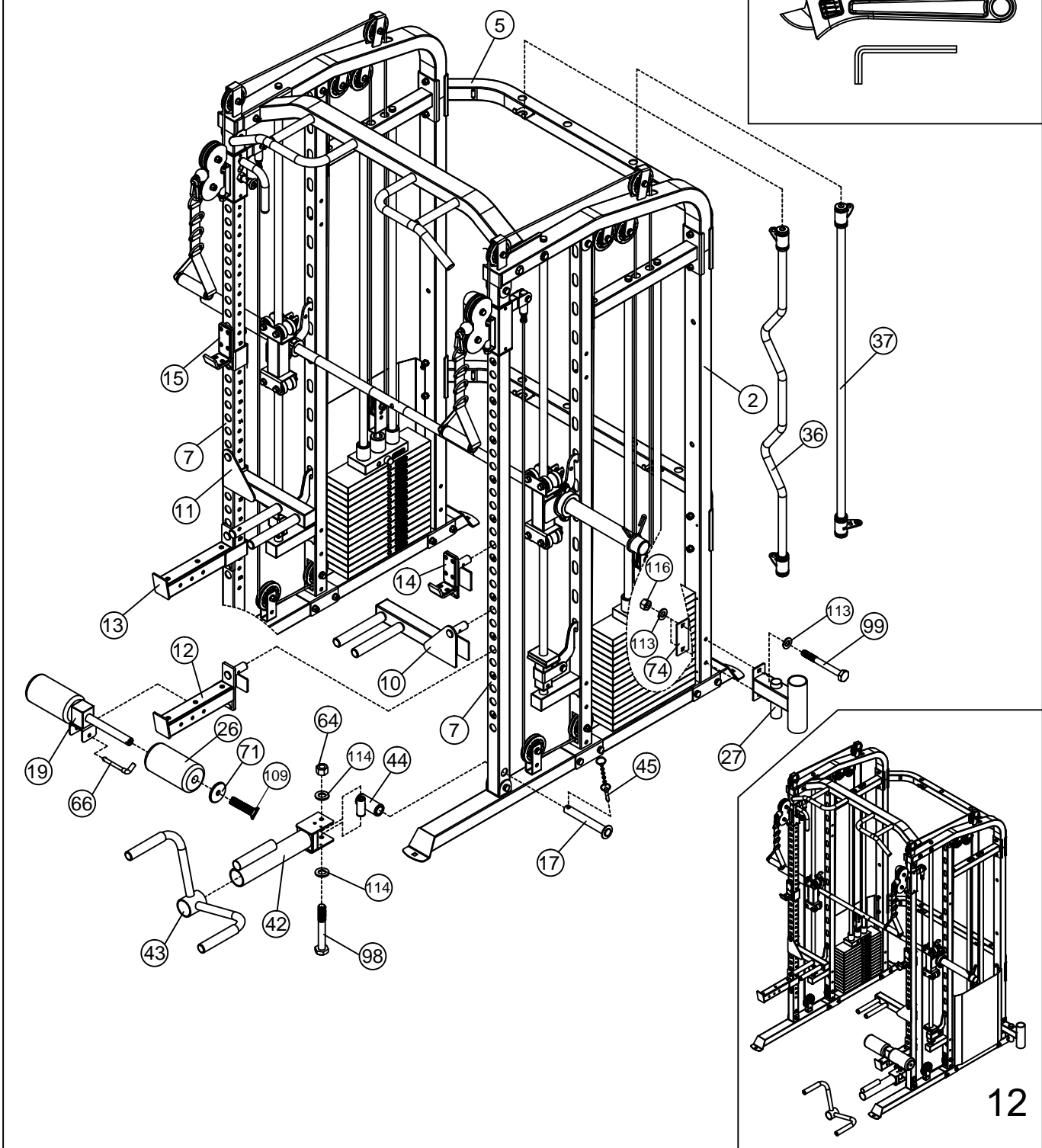
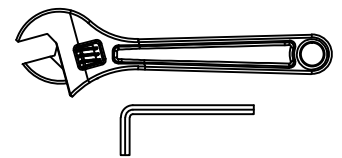

105

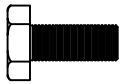

x6 M10x 25mm

113



x6 Φ10

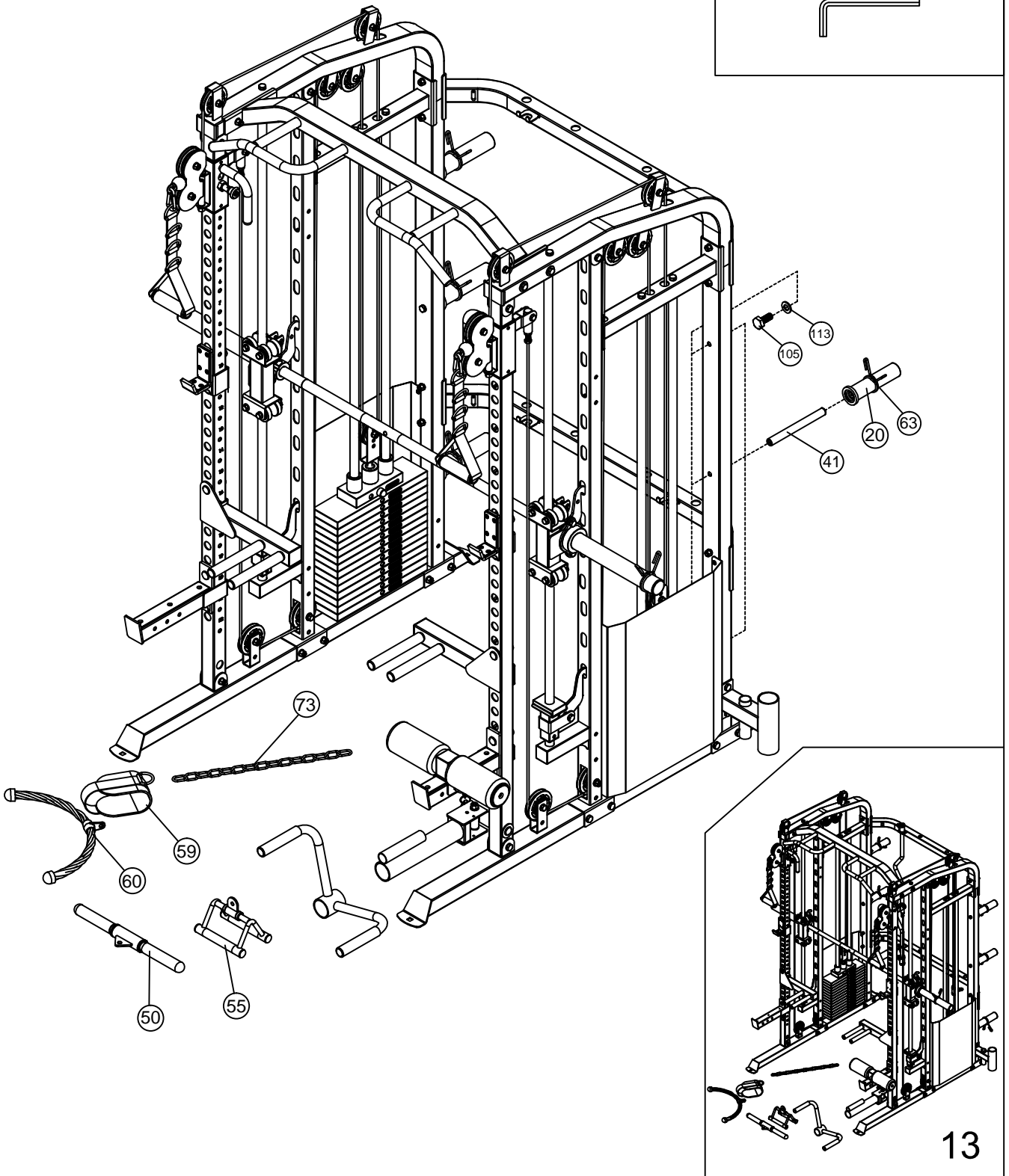
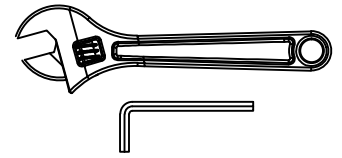

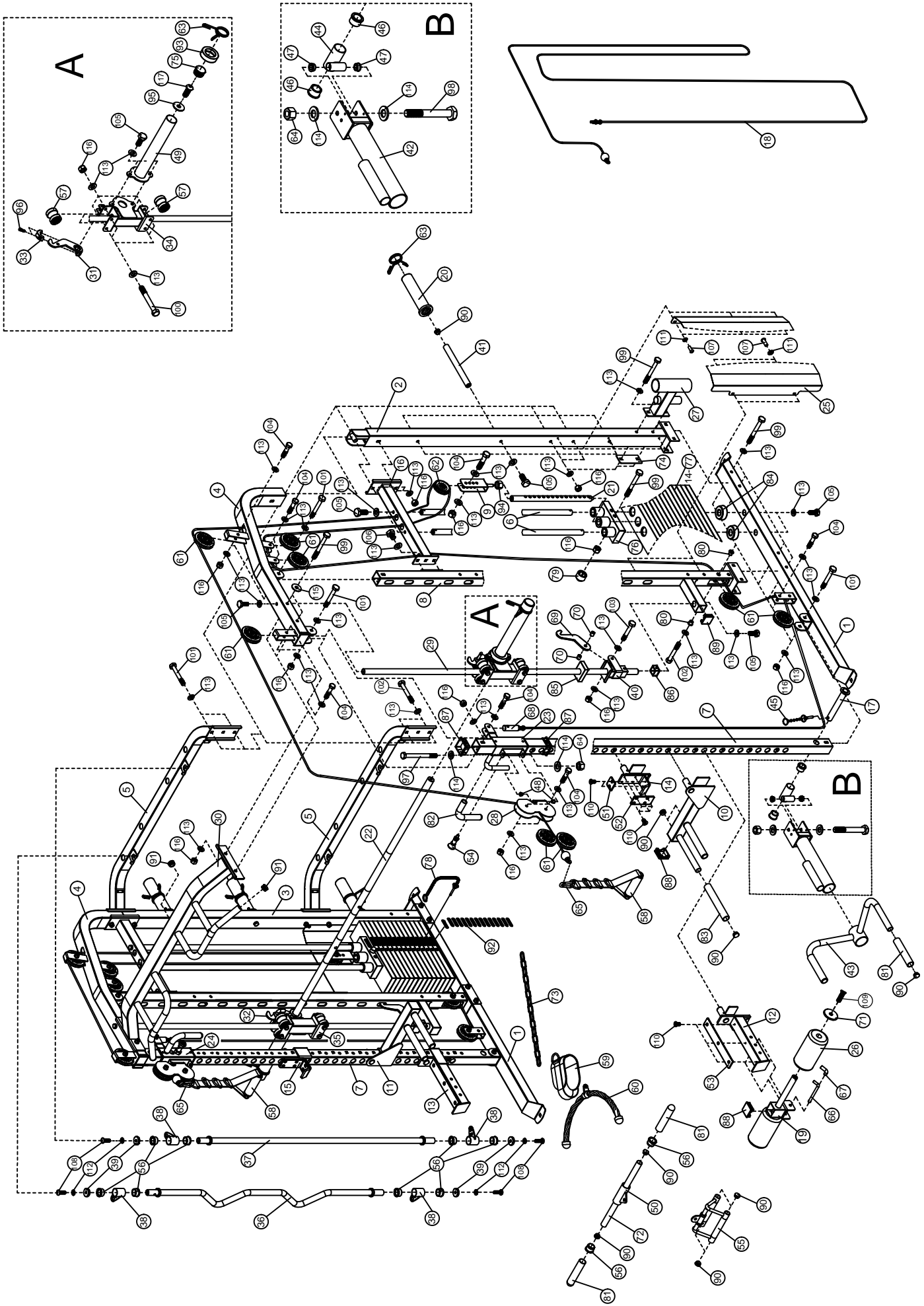

## SEZNAM ČÁSTÍ

Č.	POPIS	ROZMĚRY	POČET
1	Hlavní rám		2
2	Zadní sloupek L		1
3	Zadní sloupek p		1
4	Horní rám		2
5	Zadní spojovací rám		2
6	Zadní vodící tyč	φ25×1712	4
7	Sloupek přední vodící tyče	□50×3×1950	2
8	Středový stojan		2
9	Držák kolečka kladky		2
10	Rám pro kliky L		1
11	Rám pro kliky P		1
12	Dlouhý bezpečnostní rám L		1
13.	Dlouhý bezpečnostní rám P		1
14	Krátký bezpečnostní rám L		1
15	Krátký bezpečnostní rám P		1
16	Spojovací rám		2
17	Otočný klínek	φ25×183	1
18	Dvojitě lanko	L=8020mm	2
19	Rám pěnovky		1
20	Krátká redukce pro olymp.kotouč		6
21	Tyč pro výběr závaží		2
22	Hřídel	φ30×1865	1
23	Pojezd rámu L		1
24	Pojezd rámu P		1
25	Kryt		2
26	Pěnovka	φ95×φ22×180	2
27	Držák hřídele		1
28	Kryt kolečka kladky		2
29	Vodící lišta	φ25×1770	2
30	Horizontální rám		2
31	Hák L		1
32	Hák P		1
33	Půlkulaté pevné uchycení		2
34	Stojan válečku L		1
35	Stojan válečku P		1
36	Lomená hřídel (příslušenství)		1
37	Rovná hřídel (příslušenství)		1
38	Prstenec		4
39	Krytka hřídele	φ38×φ9×8	4
40	Podpěra bezpečnostního háku		2
41	Tyč pro závaží	φ25×245	6
42	Otočný rám		1
43	Úchop		1
44	Distanční prvek		1
45	Klínek		1
46	Pouzdro	φ38×φ34×φ25×22	2
47	Pouzdro	φ25×φ21.8×φ12.2×8	2
48	Pouzdro	φ19×φ16×φ12×8	4
49	Dlouhý rukáv na stojan hřídele	φ50×350	2
50	Rám malé hřídele		1

## SEZNAM ČÁSTÍ

ČÍSLO	POPIS	ROZMĚRY	POČET
51	Destička	52×45×5	2
52	Destička	110×52×5	2
53	Destička	280×45×5	2
54	Blokační šroub		2
55	„V” adaptér		1
56	Pouzdro	φ38×φ34×φ27×26	10
57	Skupina válečků		8
58	Úchop s nylonovým popruhem		2
59	Popruh na kotník	PH1300	1
60	Lanový adaptér		1
61	Kolečko s ložisky	φ96	16
62	Malé kolečko s ložisky	φ75×25	2
63	Pružinová svorka	φ49	8
64	Matice	M12	3
65	Karabina	φ8	2
66	Blokační „L” klínek	φ10×115	1
67	Gumový rukáv	φ13×φ9.5×58	1
68	Regulační osa	φ25×75	2
69	Bezpečnostní hák	R25×φ11×6	2
70	Distanční prvek	φ16×φ11×16	4
71	Podložka pěnovky	φ68×5	2
72	Malá hřídel	φ25×1.5×370	1
73	Řetěz (15 oček)		1
74	Podpůrná destička		1
75	Krytka		2
76	Destička selektoru		2
77	Závaží		28
78	Klínek pro výběr závaží		2
79	Krytka šroubu		2
80	Krytka kolečka		4
81	Krátký úchop pro kliky	φ23×150	4
82	Úchop pro kliky	φ24×φ18×227	2
83	Úchop pro kliky	φ23×200	4
84	Gumový tlumič	φ62×φ24.5×25	4
85	Gumový tlumič	80×56×20	2
86	Pojezd vzpěry bezpečnostního háku	38×26×30×3	2
87	Posuvník	□60×2.5×□50×25	4
88	Krytka	□50	3
89	Krytka	□45	2
90	Krytka	φ25	22
91	Krytka	φ28	6
92	Nálepky	51×13	2
93	Tlumící podložka	φ78×φ47.5×23	2
94	Hexagonální matice	M12	2
95	Podložka	φ37×φ13.5×3	2
96	Válečkový šroub	M8×20	4
97	Hexagonální šroub	M12×135	2
98	Hexagonální šroub	M12×90	1
99	Hexagonální šroub	M10×90	16
100	Hexagonální šroub	M10×85	8



## SEZNAM ČÁSTÍ

Č.	POPIS	ROZMĚRY	POČET
101	Hexagonální šroub	M10×75	10
102	Hexagonální šroub	M10×70	6
103	Hexagonální šroub	M10×65	2
104	Hexagonální šroub	M10×45	18
105	Hexagonální šroub	M10×25	22
106	Hexagonální šroub	M10×15	4
107	Samořezný šroub	M6×16	10
108	Imbusový šroub	M8×25	4
109	Imbusový šroub	M8×35	2
110	Hexagonální šroub	M6×12	18
111	Podložka	6	10
112	Podložka	8	4
113	Podložka	10	142
114	Podložka	12	6
115	Podložka	φ30×φ10.5×2.5	4
116	Matice	M10	64
117	Imbusový šroub	M10×25	2
	Imbusový klíč	6#	1
	Imbusový klíč	5#	1
	Imbusový klíč	4#	1

Nazwa artykułu:

Kod EAN:

Data sprzedaży:

**WARUNKI GWARANCJI**

1. Sprzedawca w imieniu Gwaranta udziela gwarancji na terytorium RP na okres 24 miesięcy od daty sprzedaży.
2. Gwarancja będzie respektowana przez sklep lub serwis po przedstawieniu przez klienta:
  - czytelnie i poprawnie wypełnionej karty gwarancyjnej z pieczętką sprzedaży oraz podpisem sprzedawcy
  - ważnego dowodu zakupu sprzętu z datą sprzedaży / rachunku /
  - reklamowanego towaru
3. Ewentualne wady i uszkodzenia ujawniane w okresie gwarancyjnym będą naprawiane bezpłatnie w terminie nie dłuższym niż 21 dni od daty dostarczenia towaru do sklepu lub serwisu.
4. W przypadku konieczności sprowadzenia części z importu okres gwarancji może się wydłużyć o czas niezbędny do jej sprowadzenia jednak nie dłużej niż o 40 dni.
5. Gwarancją nie są objęte:
  - Uszkodzenia mechaniczne i wywołane nimi wady,
  - uszkodzenia i wady wynikłe wskutek niewłaściwego z przeznaczeniem użytkowania i przechowywania,
  - niewłaściwy montaż i konserwacja,
  - uszkodzenia i zużycie takich elementów jak: linki, paski, elementy gumowe, pedały, uchwyty z gąbki, kółka, łożyska itp.
6. Gwarancja traci ważność w przypadku:
  - Upięty terminu ważności,
  - samodzielnych napraw,
  - nieprzestrzegania zasad prawidłowej eksploatacji.
7. Duplikaty karty gwarancyjnej nie będą wydawane.
8. Produkt oddany do naprawy powinien być kompletny i czysty. W przypadku stwierdzenia braków ,serwis ma prawo odmówić przyjęcia do naprawy . W przypadku dostarczenia brudnego produktu serwis może odmówić jego przyjęcia lub też na koszt klienta za jego pisemną zgodą dokonać czyszczenia.
9. Gwarancją nie są objęte czynności związane z montażem ,konserwacją które zgodnie z instrukcją obsługi użytkownik zobowiązany jest wykonać we własnym zakresie.
10. Gwarant informuje również, że prowadzi serwis pogwarancyjny.
11. Towar powinien być w oryginalnym opakowaniu i zabezpieczony do wysyłki.

Gwarancja na sprzedany towar nie wyłącza, nie ogranicza ani nie zawiesza uprawnień kupującego wynikających z niezgodności towaru z umową.

**SPRZĘT NIE JEST PRZEZNACZONY DO UŻYTKU W CELACH REHABILITACYJNYCH I TERAPEUTYCZNYCH.****ADNOTACJE O PRZEBIEGU NAPRAW**

L.p.	Data zgłoszenia	Data wydania	Przebieg napraw	Podpis odbierającego (sklep, właściciel)

**Mimo iż dopełniamy wszelkich starań by zapewnić najlepszą jakość naszych produktów mogą pojawić się pojedyncze błędy lub przeoczenia. Jeśli zauważą Państwo defekt lub brak części prosimy o kontakt.**

IMPORTER: **ABISAL SP. Z O.O.**;  
ul. św. Elżbiety 6, 41-905 Bytom, POLSKA  
abisal@abisal.pl  
www.abisal.pl

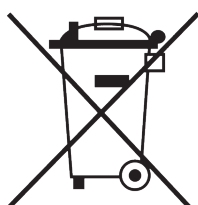

Oznakowanie sprzętu symbolem przekreślonego kontenera na odpady informuje o zakazie umieszczania zużytego sprzętu elektrycznego i elektronicznego wraz z innymi odpadami. Zgodnie z Dyrektywą WEE o sposobie gospodarowania zużytymi odpadami elektrycznymi i elektronicznymi, dla tego typu sprzętu należy stosować oddzielne sposoby utylizacji.

Użytkownik, który zamierza pozbyć się tego produktu, zobowiązany jest do oddania go do punktu zbierania zużytego sprzętu elektrycznego i elektronicznego, dzięki czemu przyczynia się do ponownego użycia, recyklingu, bądź odzysku, a tym samym do ochrony środowiska naturalnego. W tym celu należy skontaktować się z punktem w którym urządzenie zostało nabyte, lub z przedstawicielami władz lokalnych. Składniki niebezpieczne zawarte w sprzęcie elektronicznym mogą powodować długo utrzymujące się niekorzystne zmiany w środowisku naturalnym, jak również działać szkodliwie na zdrowie ludzi.

Article name:

EAN code:

Date of sale:

**GUARANTEE TERMS**

1. The Seller provides guarantee on behalf of the Guarantor within the territory of the Republic of Poland for the period of 24 months from the date of sale.
2. The Guarantee will be recognised by the shop or service centre after the client provides:
  - clearly and correctly filled-in guarantee card with the sale stamp and the seller's signature
  - valid purchase confirmation for the equipment including the date of sale / bill /
  - complained product.
3. Possible defects and damages revealed during the guarantee period shall be remedied free of charge within not more than 21 days from the delivery of the product to the shop or service.
4. Should it be necessary to import some components, the guarantee term can be extended by the period required to import such part, however such period shall not be longer than 40 days.
5. The guarantee does not cover:
  - mechanical damages and subsequent defects,
  - damages and defects resulting from incorrect storage and usage of the equipment against its purpose,
  - incorrect assembly and maintenance,
  - damages and consumption of such elements as: cables, straps, rubber parts, pedals, sponge grips, wheels, bearings, etc.
6. The guarantee expires in the event of:
  - expiry of the validity term,
  - self-repairs,
  - failure to follow the rules of correct operation.
7. No duplicates of the guarantee cards shall be issued.
8. The product handed over for repair should be complete and clean. If some parts are missing, the service is entitled to refuse to accept the product for repair. The service may refuse to accept a dirty product or clean in on the client's expense after the client's written permit.
9. The guarantee does not cover activities related to assembly, maintenance, which, according to the instruction, the user is obliged to perform themselves.
10. The Guarantor also informs that they offer post-guarantee service.
11. The product should be provided in its original packaging and should be secured for shipment.

The guarantee for sold goods is not exclusive, does not limit or suspend entitlements of the buyer resulting from the non-compliance of the product with the agreement.

**THE EQUIPMENT IS NOT INTENDED FOR REHABILITATION AND THERAPY**

**NOTES ON THE COURSE OF REPAIRS**

Item	Date of notification	Date of provision	Course of repairs	Signature of the recipient (shop, owner)

**Even though we do our best to ensure the highest quality of our products, single defects or omissions might occur. If you note a defect or missing part, we invite you to contact us.**

IMPORTER: **ABISAL SP. Z O.O.**;  
 ul. św. Elżbiety 6, 41-905 Bytom, POLSKA  
 abisal@abisal.pl  
 www.abisal.pl



Labelling the product with a symbol of a crossed waste container informs us that the worn-out electrical and electronic equipment cannot be put into the same container as other waste. According to the WEEE Directive on the management of electrical and electronic waste, separate recycling methods shall be used for this type of equipment. A user who wants to dispose of such product is obliged to transfer it to the collection centre for worn-out electrical and electronic equipment, thanks to which they support its re-usage, recycling or recovery and thusly protect natural environment. For this purpose, one should contact the equipment seller or representatives of local authorities. Hazardous components contained in electronic equipment may have long-lasting harmful impact on natural environment as well as adverse effect on human health.

Název produktu:	
EAN kód:	
Datum prodeje:	

### ZÁRUČNÍ PODMÍNKY

1. Prodávající jménem Ručitele poskytuje záruku na území Polska po dobu 24 měsíců od data prodeje.
2. Záruka bude respektována obchodem nebo servisem po předložení zákazníkem:
  - čitelně a správně vyplněného záručního listu s razítkem a podpisem prodávajícího
  - platného doklad o koupi produktu s datem prodeje (účtu)
  - reklamovaného produktu
3. Jakékoli závady a poškození odhalené během záruční doby budou opraveny bezplatně nejdéle do 21 dnů ode dne doručení do obchodu nebo servisu.
4. Je-li třeba produkt převézt z jiné země, může být záruční lhůta prodloužena o dobu nezbytnou k jeho vrácení, nejdéle však o 40 dnů.
5. Záruka se nevztahuje na:
  - mechanické poškození a vady způsobené nimi
  - poškození a vady vyplývající z nesprávného použití a skladování
  - špatnou montáž a údržbu
  - poškození a opotřebení součástí které podléhají zkáze, jako jsou kabely, pásy, pryžové prvky, pedály, držáky na houby, kola, ložiska atd.
6. Záruka zaniká, pokud:
  - vyprší její platnost
  - bylo do produktu neodborně zasaženo
  - nebyla dodržena pravidla řádné údržby
7. Duplikáty záručního listu nebudou vydány.
8. Produkt dodaný do opravy by měl být kompletní a čistý, v opačném případě má servis právo odmítnout přijetí produktu do opravy. V případě dodání špinavého produktu může servis odmítnout jeho přijetí do opravy, nebo na náklady zákazníka stroj vyčistit s jeho písemným svolením k čištění.
9. Záruka se nevztahuje na činnosti související s montáží a údržbou, které musí podle uživatelské příručky provádět sám uživatel.
10. Ručitel také informuje, že provozuje pozáruční servis.
11. Výrobek by měl být v původním obalu a zajištěn pro přepravu.

Záruka na prodané zboží nevylučuje, neomezuje nebo nezavazuje práva kupujícího vyplývající z nedodržení záručních podmínek.

### ZAŘÍZENÍ NENÍ URČENO K POUŽITÍ PRO RAHABILITAČNÍ A TERAPEUTICKÉ ÚČELY.

### UPOZORNĚNÍ O OPRAVĚ

Č.	Datum nahlášení	Datum vydání	Průběh oprav	Podpis příjemce (obchod, majitel)

**Přesto, že děláme vše pro to, abychom zajistili maximální kvalitu našich výrobků, mohou se objevit jednotlivé vady nebo chyby. Pokud si všimnete závady nebo toho, že některá z částí chybí, kontaktujte nás, prosím.**

DOVOZCE: **ABISAL SP. Z O.O.**;  
 ul. św. Elżbiety 6, 41-905 Bytom, POLSKA  
 abisal@abisal.pl  
 www.abisal.pl



Označení zařízení symbolem přeškrtnutého kontejneru na odpady informuje o zákazu likvidace použitého elektrického a elektronického zařízení společně s jinými odpady. V souladu se Směrnicí WEE o způsobu nakládání s elektrickými a elektronickými odpady, je potřeba pro tento druh zařízení používat oddělené způsoby jejich likvidace. Uživatel, který se chce tohoto zařízení zbavit, je povinen jej odevzdat ve sběrném dvoře pro elektrický a elektronický odpad, díky čemu se spolupodílí na jejich opětovném využití, recyklaci a tím i ochraně životního prostředí. Za tímto účelem kontaktujte místo, kde bylo zařízení koupeno nebo místní úřady. Nebezpečné složky obsažené v elektrickém a elektronickém zařízení mohou dlouhodobě negativně působit na životní prostředí a také zdraví lidí.





---

IMPORTER:

**ABISAL SP. Z O.O.**

ul. św. Pyskowicka 17, 41-807 Zabrze, POLSKA

DISTRIBUTOR:

**ABISTORE SPORT S.R.O**

U Cihelny 3, 748 01 Hlučín, ČESKÁ REPUBLIKA